

Approval Sheet

(產品承認書)

產品名稱	(Product)	<u>Bluetooth Low Energy Module</u>
解決方案	(Solution)	<u>Nordic nRF52833 aQFN Package</u>
產品型號	(Model No.)	<u>MDBT50Q – U512K (u.FL Connector)</u>
產品料號	(Part No.)	<u>see 4.3 Order Code</u>

Working distance of MDBT50Q-U in open space:

- Working distance in open space:*
 - 125K bps: over 750 meters
 - 1M bps: over 300 meters
- Declaration ID includes all Nordic applied profiles.*
- Four selected antennas to use directly with certification approval. See [7. Antenna](#)*

Index

1. Overall Introduction	4
1.1. Application	4
1.2. Features	5
2. Product Dimension	7
2.1. PCB Dimensions & Pin Indication	7
2.2. Recommended Layout of Solder Pad	8
2.3. RF Layout Suggestion (aka Keep-Out Area)	10
2.4. Footprint & Design Guide	11
2.5. Pin Assignment	12
2.6. GPIO Located Near the Radio	15
3. Main Chip Solution	15
4. Shipment Packaging Information	16
4.1. Marking on Metal Shield	17
4.2. Packaging Info	18
4.3. Order Code	20
5. Specification	21
5.1. Absolute Maximum Ratings	21
5.2. Operating Conditions	21
5.3. Electrical Specifications	22
6. Block Diagram	28
7. Antenna	29
8. Reference Circuit	30
8.1. Reg0 LDO Mode	31
8.2. Reg0 LDO Mode Disabled	33
8.3. USB Powered	35
8.4. USB Disabled	37
9. Certification	39
9.1. Declaration ID	39
9.2. FCC Certificate (USA)	41
9.3. TELEC Certificate (Japan)	42
9.4. NCC Certificate (Taiwan)	44
9.5. CE (EU) & RCM (Australia & New Zealand) Test Report	45
9.6. IC Certificate (Canada)	48

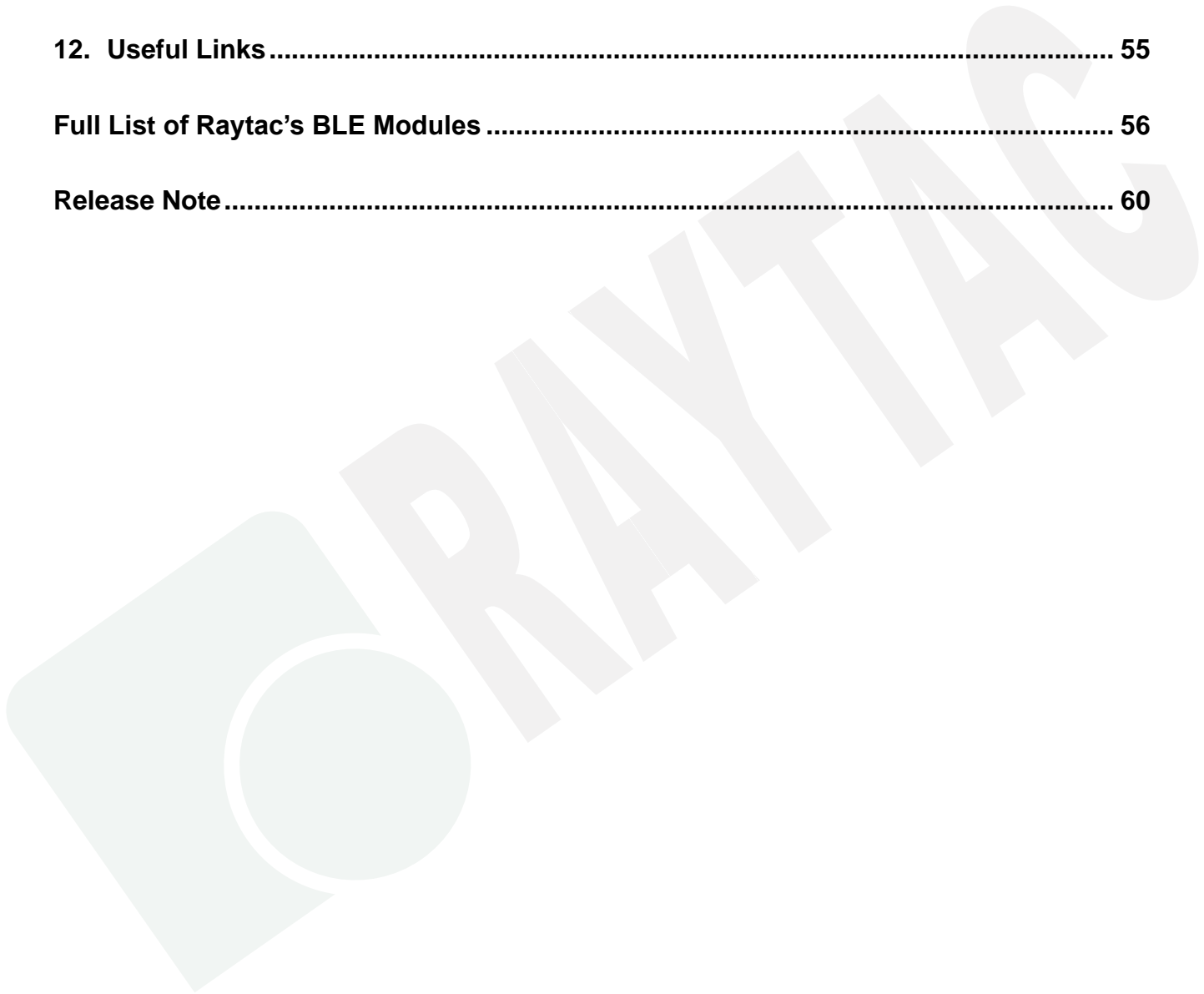

9.7. SRRC Certificate (China).....	49
9.8. KC Certificate (South Korea)	50
9.9. RoHS & REACH Report	51
9.10. End-Product Label.....	51
10. Notes and Cautions.....	53
11. Basic Facts for nRF52 Family	54
12. Useful Links.....	55
Full List of Raytac’s BLE Modules	56
Release Note.....	60



1. Overall Introduction

Raytac's MDBT50Q-U is a BT 5.2 stack (Bluetooth low energy or BLE) module designed based on **Nordic nRF52833 SoC solution**, which incorporates: **GPIO, SPI, UART, I2C, I2S, PMD, PWM, ADC, NFC** and **USB** interfaces for connecting peripherals and sensors.

Features:

1. Embedded 2.4GHz transceiver supports Bluetooth 5.2 ( **Bluetooth**), IEEE 802.15.4 ( **THREAD** & Zigbee) & 2.4Ghz RF & ANT+ upon customer's preference.
2. Compact size with **(L) 15.5 x (W) 10.5 x (H) 2.05 mm**.
3. Low power requirements, ultra-low peak, average and idle mode power consumption.
4. Be compatible with a large installed base of mobile phones, tablets and computers.
5. Fully coverage of BLE software stack.
6. BLE & RF transmission switching helps products fit all operation system and most hardware.

1.1. Application

- IoT Networks
 - Smart home (such as door locks, lighting) sensors and controllers
 - Smart city sensor networks
 - Industrial IoT sensors and controllers
 - Connected white goods
- Personal Area Networks
 - Health / fitness sensor and monitor device
 - Medical device
- Interactive entertainment devices
 - Advanced remote controls
 - Gaming controller
- Advanced wearables
 - Connected watches
 - Advanced personal fitness devices
 - Wearables with wireless secure payment
 - Connected Health
 - Virtual/Augmented Reality applications
- High performance HID Controllers
- Mesh Network

1.2. Features

- Bluetooth 5.1, IEEE 802.15.4, 2.4 GHz transceiver
 - -95dBm sensitivity in 1Mbps Bluetooth low energy (BLE) mode
 - -103dBm sensitivity in 125Kbps BLE mode (long range)
 - +8 dBm TX power (down to -20 dBm in 4 dB steps)
 - On-air compatible with nRF52, nRF51, nRF24L and nRF24AP Series
 - Programmable output power from +8dBm to -20dB
 - RSSI (1dB resolution)
 - Supported data rates:
 - Bluetooth 5.1: 2 Mbps, 1 Mbps, 500 kbps, 125 kbps
 - IEEE 802.15.4-2006: 250 kbps
 - Proprietary 2.4 GHz: 2 Mbps, 1 Mbps
 - Angle-of-arrival (AoA) and angle-of-departure (AoD) direction finding using Bluetooth®.
- ARM Cortex –M4 32-bit processor with FPU, 64 MHz
- Memory: 512KB flash / 128KB RAM
- HW accelerated security
 - 128 bit AES / ECB / CCM / AAR co-processor (on-the-fly packet encryption)
- Advanced on-chip interfaces
 - USB 2.0 full speed (12Mbps) controller
 - High speed 32MHz SPI
 - Type 2 near field communication (NFC-A) tag with wake-on field
 - Programmable peripheral interconnect (PPI)
 - 42 general purpose I/O pins
 - EasyDMA automated data transfer between memory and peripherals.
- 12 bit, 200ksps ADC – 8 configurable channels with programmable gain
- 4 x 4 channel pulse width modulator (PWM) units with EasyDMA
- Audio peripherals : I2S, digital microphone interface (PDM)
- 5 X 32-bit timers with counter mode
- Up to 4 x SPI masters / 3 x SPI slaves with EasyDMA
- Up to 2 x I2C compatible 2-wire masters / slaves
- 2 x UART(CTS/RTS) with EasyDMA
- Quadrature decoder (QDEC)
- 3 x 24-bit real-time counters (RTC)

- Flexible power management
 - Supply voltage range 1.7V to 5.5V
 - On-chip DC/DC and LDO regulators with automated low current modes
 - Automated peripheral power management
 - Fast wake-up using 64MHz internal oscillator
 - 0.4uA at 3V in System OFF mode, no RAM retention
 - 1.5uA at 3V in System ON mode, no RAM retention, wake on RTC
- Nordic SoftDevice ready and with support for concurrent multi-protocol
- Operating temperature from -40 to 105 °C



2. Product Dimension

2.1. PCB Dimensions & Pin Indication

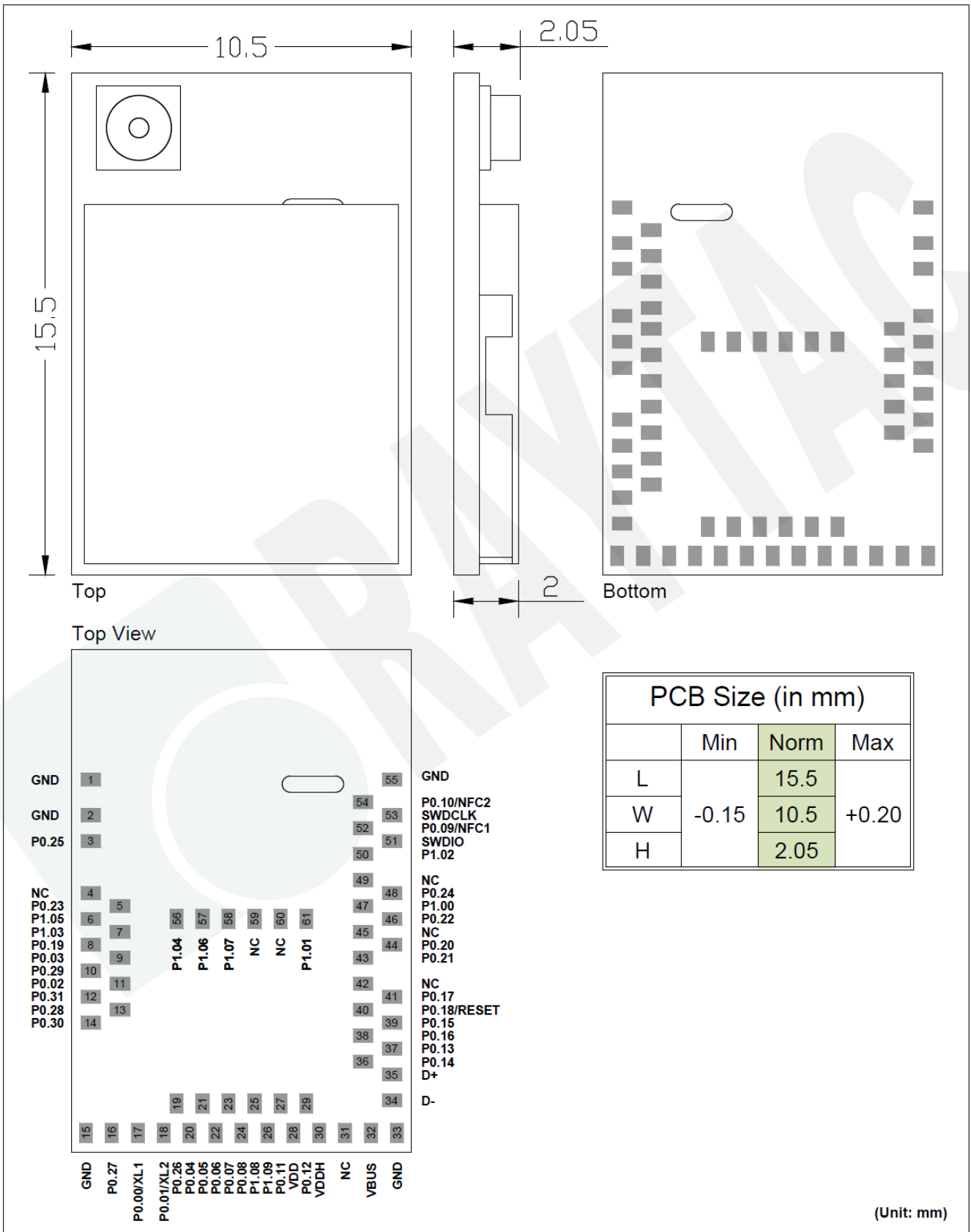

2.2. Recommended Layout of Solder Pad

Graphs are all in Top View, Unit in mm.

Top View

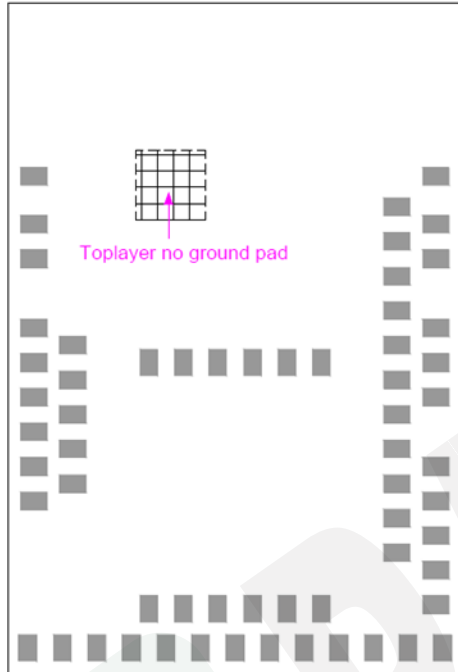

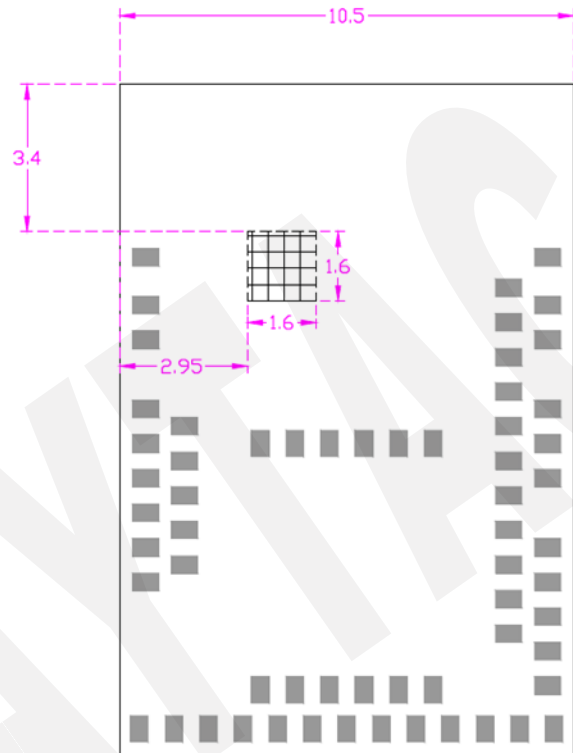

Top View (Unit: mm)

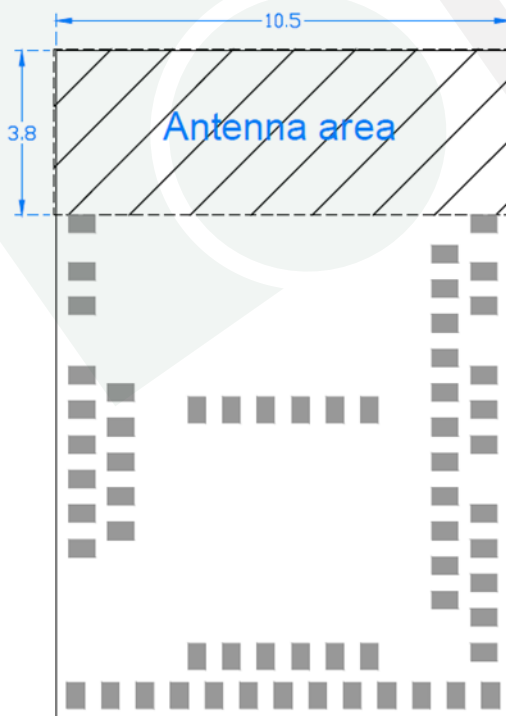

 Toplayer no ground pad

Top View (Unit: mm)



 Antenna area

Top View (Unit: mm)

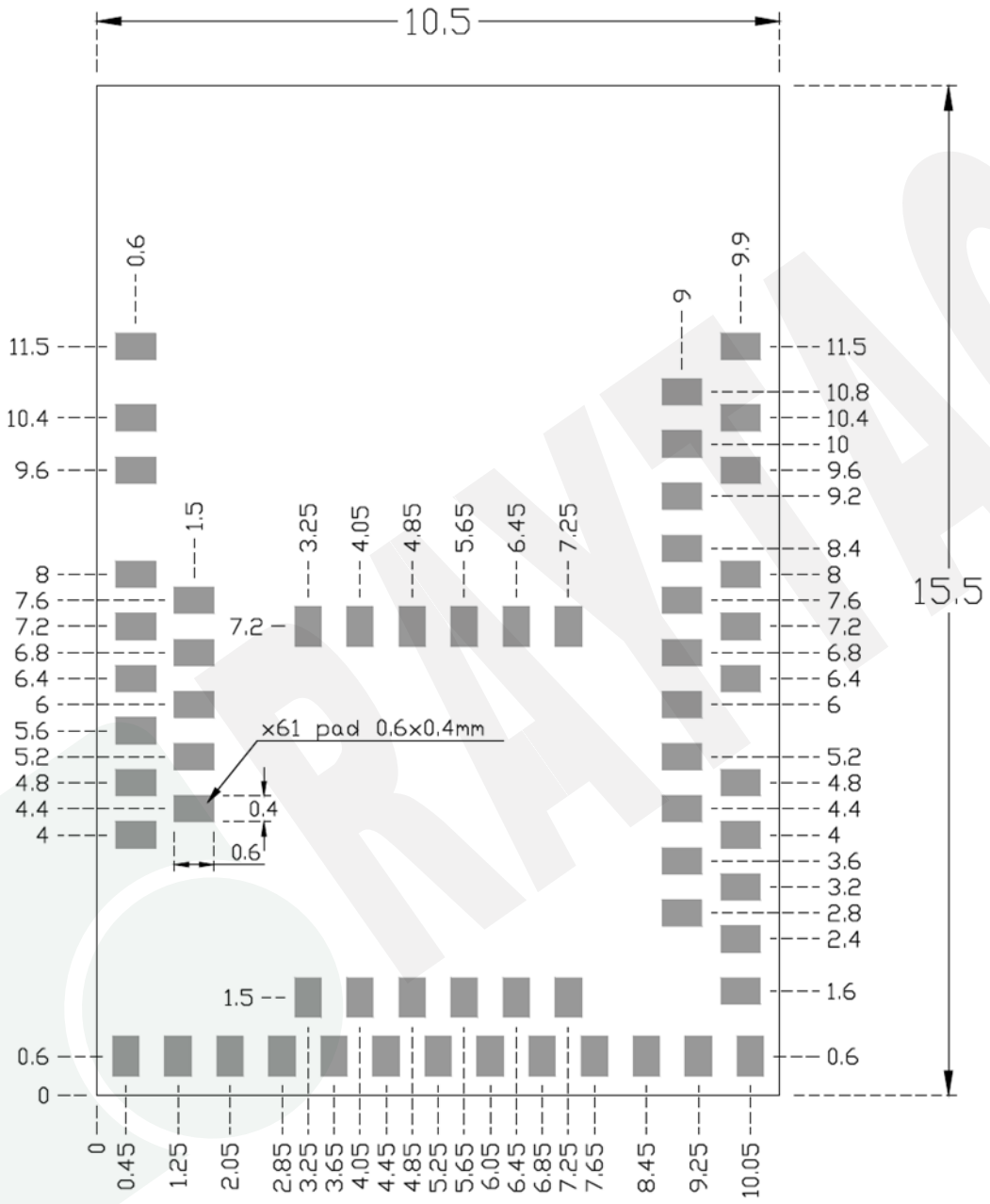

2.3. RF Layout Suggestion (aka Keep-Out Area)

Please follow below instruction to avoid from having Ground Pad in the area of our RF test pad. Otherwise, it may cause shortage to the module.

Welcome to send us your layout in PDF for review at service@raytac.com or your contact at Raytac with title "Layout reviewing – Raytac Model No. – YOUR company's name".

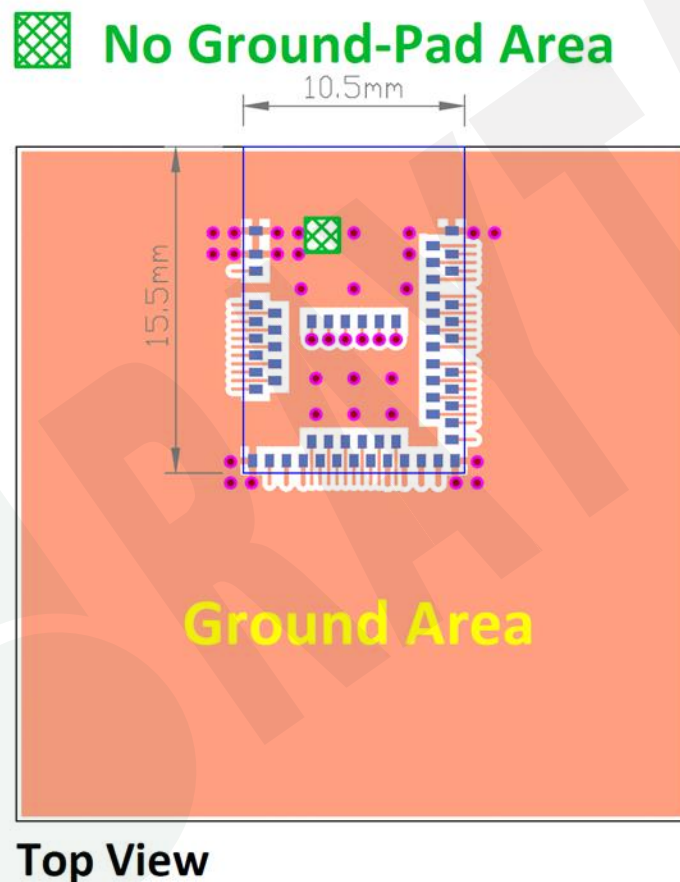

Please add via holes in GROUND area as many as possible, especially around the four corners.

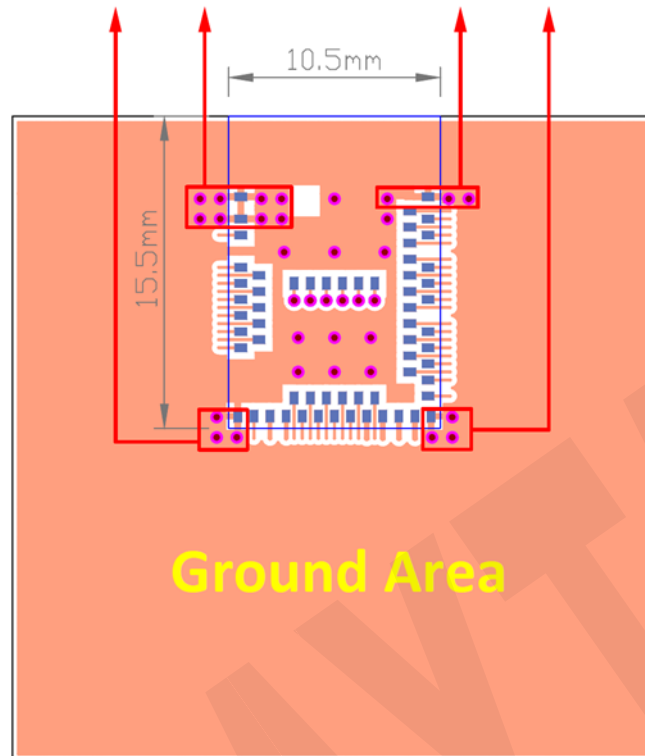

Top View

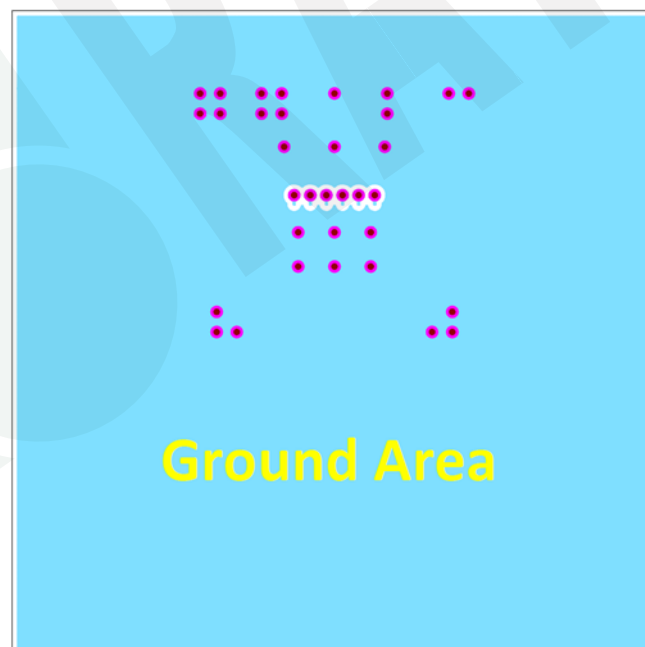

Perspective View

2.4. Footprint & Design Guide

Please visit "[Support](#)" page of our website to download. The package includes footprint, 2D/3D drawing, reflow graph/solder profile and recommended spec for external 32.768khz.

2.5. Pin Assignment

Pin No.	Name	Pin function	Description
(1)	GND	Power	Ground
(2)	GND	Power	Ground
(3)	P0.25	Digital I/O	General-purpose I/O (standard drive, low frequency I/O only)
(4)	NC		Not connected
(5)	P0.23	Digital I/O	General-purpose I/O (standard drive, low frequency I/O only)
(6)	P1.05	Digital I/O	General-purpose I/O (standard drive, low frequency I/O only)
(7)	P1.03	Digital I/O	General-purpose I/O (standard drive, low frequency I/O only)
(8)	P0.19	Digital I/O	General-purpose I/O (standard drive, low frequency I/O only)
(9)	P0.03	Digital I/O	General-purpose I/O (standard drive, low frequency I/O only)
	AIN1	Analog input	Analog input
(10)	P0.29	Digital I/O	General-purpose I/O (standard drive, low frequency I/O only)
	AIN5	Analog input	Analog input
(11)	P0.02	Digital I/O	General-purpose I/O (standard drive, low frequency I/O only)
	AIN0	Analog input	Analog input
(12)	P0.31	Digital I/O	General-purpose I/O (standard drive, low frequency I/O only)
	AIN7	Analog input	Analog input
(13)	P0.28	Digital I/O	General-purpose I/O (standard drive, low frequency I/O only)
	AIN4	Analog input	Analog input

Pin No.	Name	Pin function	Description
(14)	P0.30	Digital I/O	General-purpose I/O (standard drive, low frequency I/O only)
	AIN6	Analog input	Analog input
(15)	GND	Power	Ground
(16)	P0.27	Digital I/O	General-purpose I/O
(17)	P0.00	Digital I/O	General-purpose I/O
	XL1	Analog input	Connection for 32.768 kHz crystal
(18)	P0.01	Digital I/O	General-purpose I/O
	XL2	Analog input	Connection for 32.768 kHz crystal
(19)	P0.26	Digital I/O	General-purpose I/O
(20)	P0.04	Digital I/O	General-purpose I/O
	AIN2	Analog input	Analog input
(21)	P0.05	Digital I/O	General-purpose I/O
	AIN3	Analog input	Analog input
(22)	P0.06	Digital I/O	General-purpose I/O
(23)	P0.07	Digital I/O	General-purpose I/O
	TRACECLK	Trace clock	Trace buffer clock
(24)	P0.08	Digital I/O	General-purpose I/O
(25)	P1.08	Digital I/O	General-purpose I/O
(26)	P1.09	Digital I/O	General-purpose I/O
	TRACEDATA3	Trace data	Trace buffer TRACEDATA [3].
(27)	P0.11	Digital I/O	General-purpose I/O
	TRACEDATA2	Trace data	Trace buffer TRACEDATA[2].
(28)	VDD	Power	Power supply
(29)	P0.12	Digital I/O	General-purpose I/O
	TRACEDATA1	Trace data	Trace buffer TRACEDATA [1].
(30)	VDDH	Power	High voltage power supply
(31)	NC		Not connected
(32)	VBUS	Power	5V input for USB 3.3V regulator

Pin No.	Name	Pin function	Description
(33)	GND	Power	Ground
(34)	D-	Digital I/O	USB D-
(35)	D+	Digital I/O	USB D+
(36)	P0.14	Digital I/O	General-purpose digital I/O
(37)	P0.13	Digital I/O	General-purpose digital I/O
(38)	P0.16	Digital I/O	General-purpose digital I/O
(39)	P0.15	Digital I/O	General-purpose digital I/O
(40)	P0.18	Digital I/O	General-purpose digital I/O
	nRESET		Configurable as system RESET
(41)	P0.17	Digital I/O	General-purpose digital I/O
(42)	NC		Not connected
(43)	P0.21	Digital I/O	General-purpose digital I/O
(44)	P0.20	Digital I/O	General-purpose digital I/O
(45)	NC		Not connected
(46)	P0.22	Digital I/O	General-purpose digital I/O
(47)	P1.00	Digital I/O	General-purpose digital I/O
	TRACEDATA0	Trace data	Trace buffer TRACEDATA [0].
(48)	P0.24	Digital I/O	General-purpose digital I/O
(49)	NC		Not connected
(50)	P1.02	Digital I/O	General-purpose I/O (standard drive, low frequency I/O only)
(51)	SWDIO	Debug	Debug serial data
(52)	P0.09	Digital I/O	General-purpose I/O (standard drive, low frequency I/O only)
	NFC1	NFC input	NFC antenna connection
(53)	SWDCLK	Debug	Serial wire debug clock input for debug and programming
(54)	P0.10	Digital I/O	General-purpose I/O (standard drive, low frequency I/O only)
	NFC2	NFC input	NFC antenna connection

Pin No.	Name	Pin function	Description
(55)	GND	Power	Ground
(56)	P1.04	Digital I/O	General-purpose I/O (standard drive, low frequency I/O only)
(57)	P1.06	Digital I/O	General-purpose I/O (standard drive, low frequency I/O only)
(58)	P1.07	Digital I/O	General-purpose I/O (standard drive, low frequency I/O only)
(59)	NC		Not connected
(60)	NC		Not connected
(61)	P1.01	Digital I/O	General-purpose I/O (standard drive, low frequency I/O only)

2.6. GPIO Located Near the Radio

Please refer to [2.5 Pin Assignment](#) on page 16 to 18 where identifies some GPIO that have recommended usage. To maximize RF performance, these GPIO are only available to use under standard drive, low frequency I/O only, wrong usage may lead to undesirable performance.

Low frequency I/O is a signal with a frequency up to 10 kHz. SPI, I2C, UART, PWM are NOT low frequency I/O.

3. Main Chip Solution

RF IC	Crystal Frequency
Nordic NRF52833	32MHZ

32MHz crystal and RF (VDD) DC/DC inductor (Reg1) are already inside the module.

4. Shipment Packaging Information

Model	Antenna	Photo
MDBT50Q-U512K	u.FL Connector	

- Unit Weight of Module: 0.68 g (± 0.02 g)

- Packaging Type: Anti-static tray or Tape & Reel

	Tray	Tape & Reel
MPQ (Min. Package Q'ty)	88 pcs per tray	1,500 pcs per reel
Carton Contents (per carton)	1,760 pcs	1,500 pcs
Carton Dimension (L) x (W) x (H) cm	37 x 21 x 13	37 x 36 x 6
Gross Weight	about 2.8 kgs	about 1.9 kgs

4.1. Marking on Metal Shield

Raytac Corporation
FCC ID: SH6MDBT50Q
IC: 8017A-MDBT50QU
CMIIT ID: 2018DJ5134(M)
Model No.: MDBT50Q-U



4.2. Packaging Info

4.2.1. Tray Packaging

Anti-static tray is specifically designed for mass production. It can be used directly on SMT automatic machine.

Before July 1st, 2022

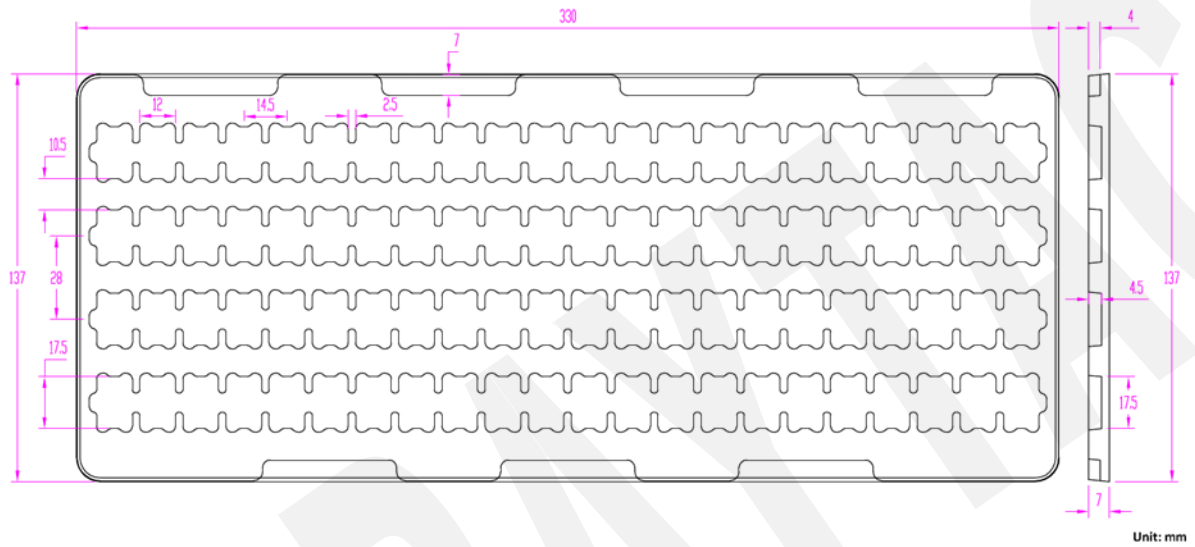

After July 1st, 2022

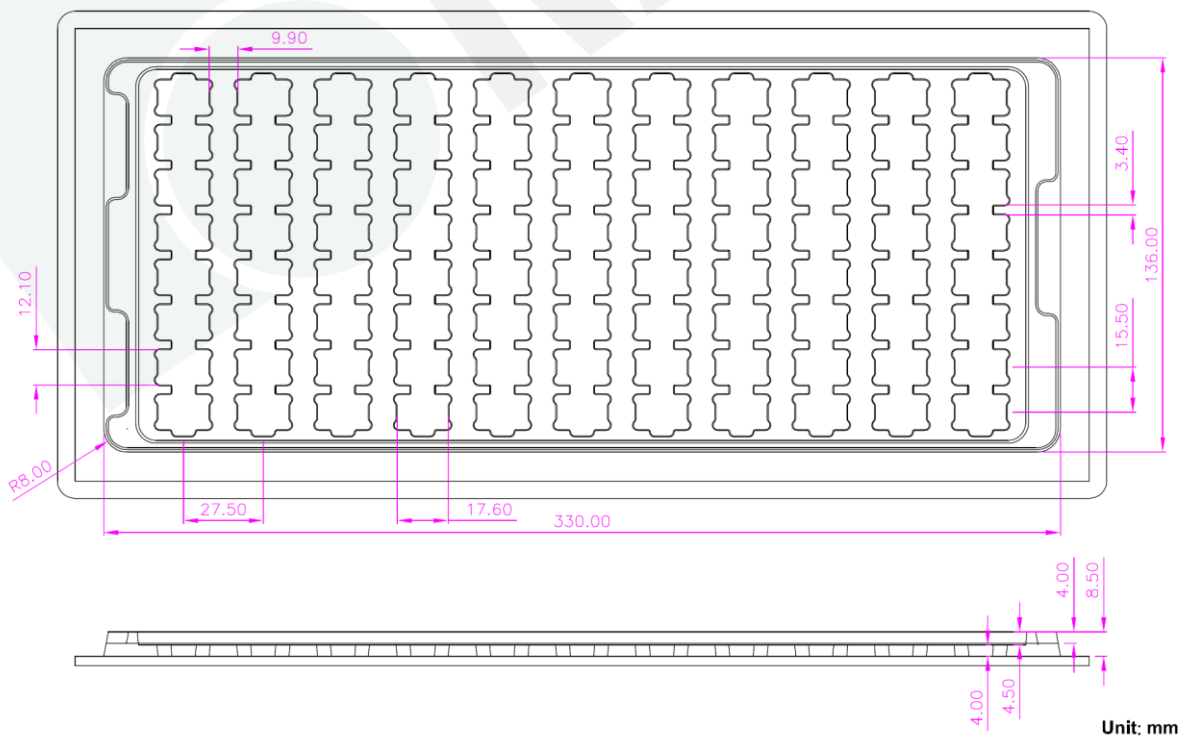

4.2.2. Tape & Reel Packaging

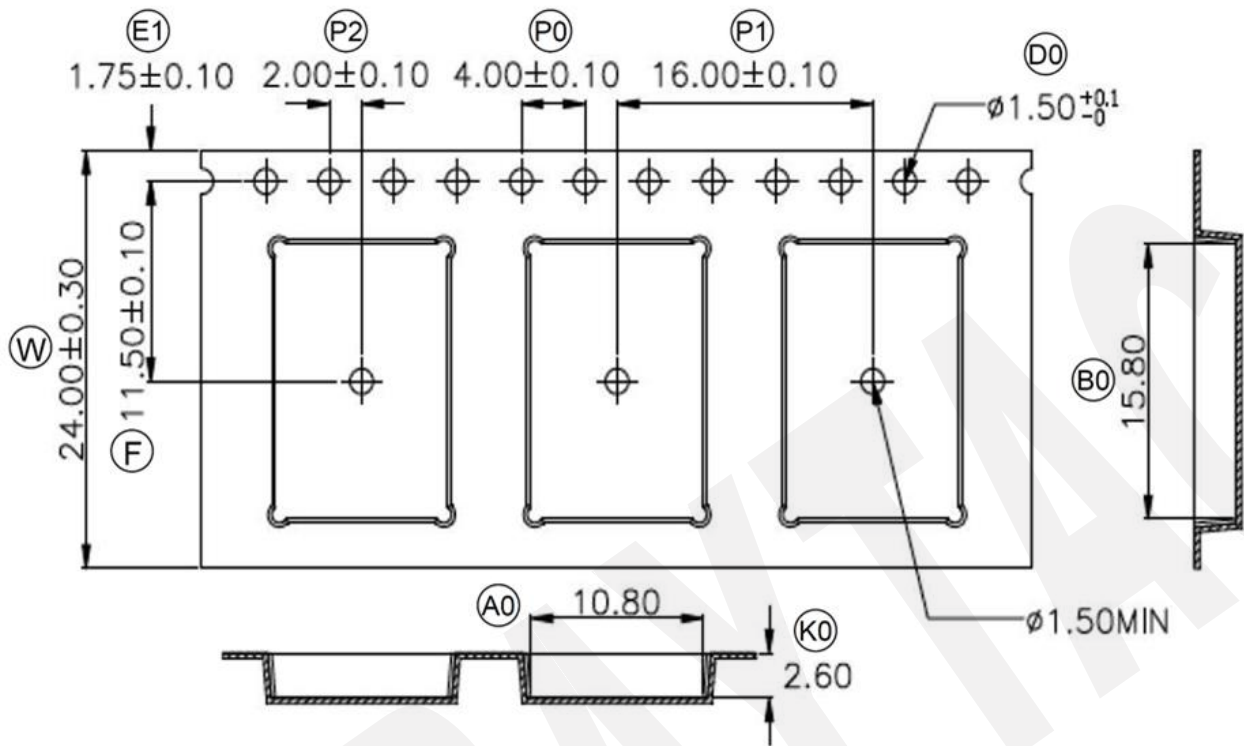

W	24.00	±0.30
P1	16.00	±0.10
E1	1.75	±0.10
F	11.50±0.10	
D0	1.50	+0.1/-0
P0	4.00	±0.10
P2	2.00±0.10	
A0	10.80	±0.10
B0	15.80	±0.10
K0	2.60	±0.10
T	0.30	±0.05

4.3. Order Code

Each model has two options of packaging. Please use following part no. when placing order to us.

Model	Tray	Tape & Reel
MDBT50Q-U512K	MD-240A3-017	MD-240A3-017R

MPQ of Reel packaging is 1,500 pcs and Tray packaging is 88 pcs.

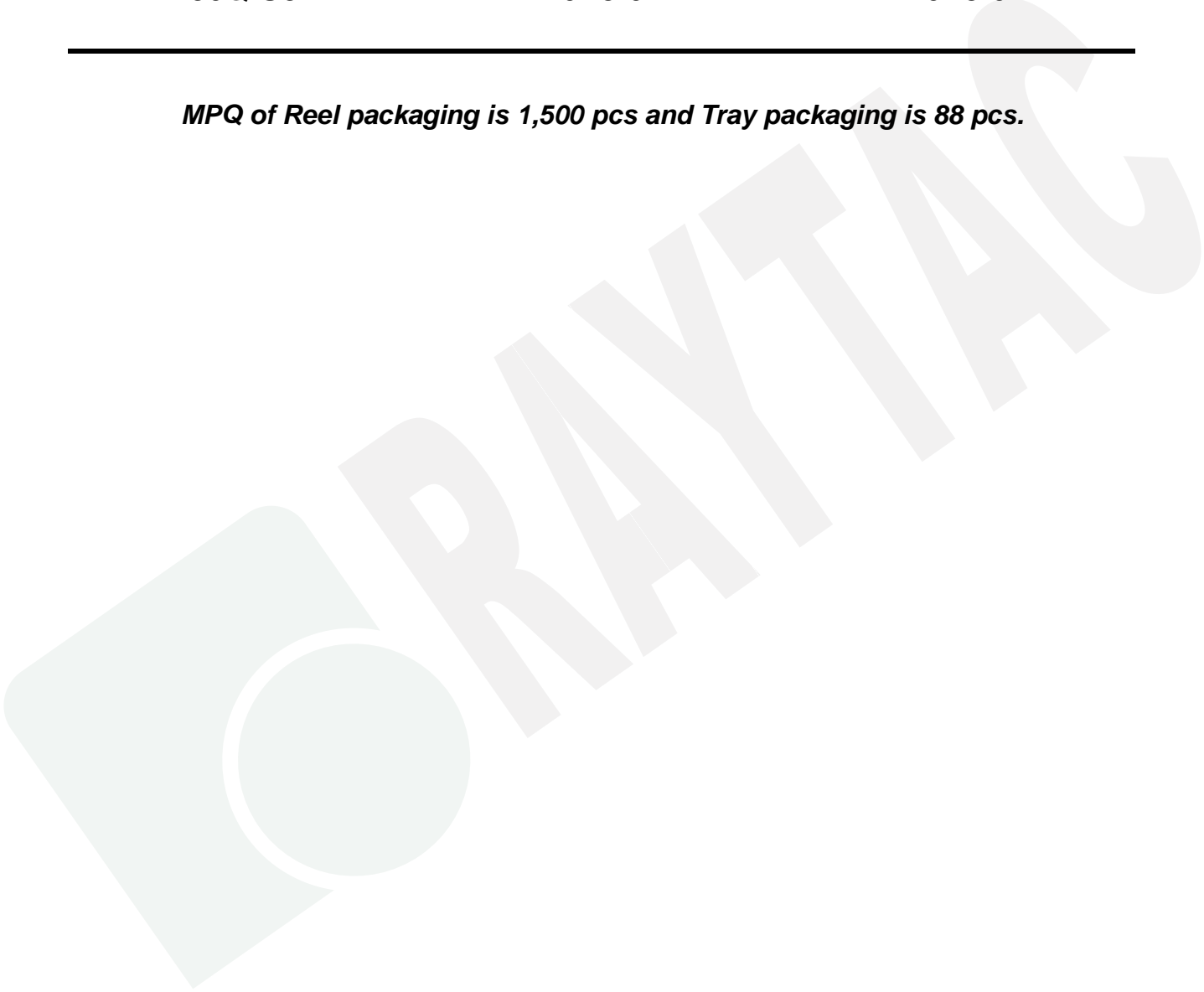

5. Specification

Any technical spec shall refer to Nordic's official documents as final reference. Contents below are from "[nRF52833 Production Specification v1.5](#)", please click to download full spec.

5.1. Absolute Maximum Ratings

	Note	Min.	Max.	Unit
Supply voltages				
VDD		-0.3	+3.9	V
VDDH		-0.3	+5.8	V
VBUS		-0.3	+5.8	V
VSS			0	V
I/O pin voltage				
$V_{I/O}$, VDD \leq 3.6 V		-0.3	VDD + 0.3	V
$V_{I/O}$, VDD > 3.6 V		-0.3	3.9	V
NFC antenna pin current				
$I_{NFC1/2}$			80	mA
Environmental aQFN™ package				
Storage temperature		-40	+125	°C
MSL	Moisture Sensitivity Level		2	
ESD HBM	Human Body Model		4	kV
ESD HBM Class	Human Body Model Class		3A	
ESD CDM	Charged Device Model		750	V
Flash memory				
Endurance		10 000		write/erase cycles
Retention at 85 °C		10		years
Retention at 105 °C	Limited to 1000 write/erase cycles	3		years
Retention at 105 °C-85 °C, execution split	Limited to 1000 write/erase cycles	6.7		years
	75% execution time at 85 °C or less			

5.2. Operating Conditions

Symbol	Parameter	Min.	Nom.	Max.	Units
VDD	VDD supply voltage, independent of DCDC enable	1.7	3.0	3.6	V
VDD _{POR}	VDD supply voltage needed during power-on reset	1.75			V
VDDH	VDDH supply voltage	2.5	3.7	5.5	V
VBUS	VBUS USB supply voltage	4.35	5.0	5.5	V
t_{R_VDD}	Supply rise time (0 V to 1.7 V)			60	ms
t_{R_VDDH}	Supply rise time (0 V to 3.7 V)			100	ms
TA	Operating temperature	-40	25	85	°C
TA _{EXT}	Extended operating temperature	85		105	°C
T _J	Junction temperature			110	°C

Note: The on-chip power-on reset circuitry may not function properly for rise times longer than the specified maximum.

5.3. Electrical Specifications

5.3.1. General Radio Characteristics

Symbol	Description	Min.	Typ.	Max.	Units
f_{OP}	Operating frequencies	2360		2500	MHz
$f_{PLL,CH,SP}$	PLL channel spacing		1		MHz
$f_{DELTA,1M}$	Frequency deviation @ 1 Mbps		± 170		kHz
$f_{DELTA,BLE,1M}$	Frequency deviation @ BLE 1 Mbps		± 250		kHz
$f_{DELTA,2M}$	Frequency deviation @ 2 Mbps		± 320		kHz
$f_{DELTA,BLE,2M}$	Frequency deviation @ BLE 2 Mbps		± 500		kHz
f_{skBPS}	On-the-air data rate	125		2000	kbps
$f_{chip, IEEE 802.15.4}$	Chip rate in IEEE 802.15.4 mode		2000		kchips

5.3.2. Radio Current Consumption (Transmitter)

Symbol	Description	Min.	Typ.	Max.	Units
$I_{TX,PLUS8dBm,DCDC}$	TX only run current (DC/DC, 3 V) $P_{RF} = +8$ dBm		14.2		mA
$I_{TX,PLUS8dBm}$	TX only run current $P_{RF} = +8$ dBm		30.4		mA
$I_{TX,PLUS4dBm,DCDC}$	TX only run current (DC/DC, 3 V) $P_{RF} = +4$ dBm		9.6		mA
$I_{TX,PLUS4dBm}$	TX only run current $P_{RF} = +4$ dBm		20.7		mA
$I_{TX,0dBm,DCDC}$	TX only run current (DC/DC, 3 V) $P_{RF} = 0$ dBm		4.9		mA
$I_{TX,0dBm}$	TX only run current $P_{RF} = 0$ dBm		10.3		mA
$I_{TX,MINUS4dBm,DCDC}$	TX only run current DC/DC, 3 V $P_{RF} = -4$ dBm		3.8		mA
$I_{TX,MINUS4dBm}$	TX only run current $P_{RF} = -4$ dBm		8.0		mA
$I_{TX,MINUS8dBm,DCDC}$	TX only run current DC/DC, 3 V $P_{RF} = -8$ dBm		3.4		mA
$I_{TX,MINUS8dBm}$	TX only run current $P_{RF} = -8$ dBm		7.1		mA
$I_{TX,MINUS12dBm,DCDC}$	TX only run current DC/DC, 3 V $P_{RF} = -12$ dBm		3.1		mA
$I_{TX,MINUS12dBm}$	TX only run current $P_{RF} = -12$ dBm		6.4		mA
$I_{TX,MINUS16dBm,DCDC}$	TX only run current DC/DC, 3 V $P_{RF} = -16$ dBm		2.9		mA
$I_{TX,MINUS16dBm}$	TX only run current $P_{RF} = -16$ dBm		5.9		mA
$I_{TX,MINUS20dBm,DCDC}$	TX only run current DC/DC, 3 V $P_{RF} = -20$ dBm		2.7		mA
$I_{TX,MINUS20dBm}$	TX only run current $P_{RF} = -20$ dBm		5.5		mA
$I_{TX,MINUS40dBm,DCDC}$	TX only run current DC/DC, 3 V $P_{RF} = -40$ dBm		2.3		mA
$I_{TX,MINUS40dBm}$	TX only run current $P_{RF} = -40$ dBm		4.5		mA
$I_{START,TX,DCDC}$	TX start-up current DC/DC, 3 V, $P_{RF} = 4$ dBm		4.3		mA
$I_{START,TX}$	TX start-up current, $P_{RF} = 4$ dBm		8.9		mA

5.3.3. Radio Current Consumption (Receiver)

Symbol	Description	Min.	Typ.	Max.	Units
$I_{RX,1M,DCDC}$	RX only run current (DC/DC, 3 V) 1 Mbps/1 Mbps BLE		4.6		mA
$I_{RX,1M}$	RX only run current (LDO, 3 V) 1 Mbps/1 Mbps BLE		9.6		mA
$I_{RX,2M,DCDC}$	RX only run current (DC/DC, 3 V) 2 Mbps/2 Mbps BLE		5.2		mA
$I_{RX,2M}$	RX only run current (LDO, 3 V) 2 Mbps/2 Mbps BLE		10.7		mA
$I_{START,RX,1M,DCDC}$	RX start-up current (DC/DC, 3 V) 1 Mbps/1 Mbps BLE		3.4		mA
$I_{START,RX,1M}$	RX start-up current 1 Mbps/1 Mbps BLE		6.8		mA

5.3.4. Transmitter Specification

Symbol	Description	Min.	Typ.	Max.	Units
P_{RF}	Maximum output power		8		dBm
P_{RFC}	RF power control range		28		dB
P_{RFCR}	RF power accuracy			± 4	dB
$P_{RF1,1}$	1st Adjacent Channel Transmit Power 1 MHz (1 Mbps)		-25		dBc
$P_{RF2,1}$	2nd Adjacent Channel Transmit Power 2 MHz (1 Mbps)		-54		dBc
$P_{RF1,2}$	1st Adjacent Channel Transmit Power 2 MHz (2 Mbps)		-26		dBc
$P_{RF2,2}$	2nd Adjacent Channel Transmit Power 4 MHz (2 Mbps)		-54		dBc
E_{vm}	Error vector magnitude IEEE 802.15.4		9		%rms
$P_{harm2nd, IEEE 802.15.4}$	2nd harmonics in IEEE 802.15.4 mode		-51		dBm
$P_{harm3rd, IEEE 802.15.4}$	3rd harmonics in IEEE 802.15.4		-51		dBm

5.3.5. RSSI Specifications

Symbol	Description	Min.	Typ.	Max.	Units
$RSSI_{ACC}$	RSSI accuracy valid range -90 to -30 dBm		± 2		dB
$RSSI_{RESOLUTION}$	RSSI resolution		1		dB
$RSSI_{PERIOD}$	RSSI sampling time from RSSI_START task		0.25		μs
$RSSI_{SETTLE}$	RSSI settling time after signal level change		15		μs

5.3.6. Receiver Operation

Symbol	Description	Min.	Typ.	Max.	Units
P _{RX,MAX}	Maximum received signal strength at < 0.1% PER		0		dBm
P _{SENS,IT,1M}	Sensitivity, 1 Mbps nRF mode ideal transmitter ¹		-93		dBm
P _{SENS,IT,2M}	Sensitivity, 2 Mbps nRF mode ideal transmitter ²		-89		dBm
P _{SENS,IT,SP,1M,BLE}	Sensitivity, 1 Mbps BLE ideal transmitter, packet length ≤ 37 bytes BER=1E-3 ³		-96		dBm
P _{SENS,IT,LP,1M,BLE}	Sensitivity, 1 Mbps BLE ideal transmitter, packet length ≥ 128 bytes BER=1E-4 ⁴		-94		dBm
P _{SENS,IT,SP,2M,BLE}	Sensitivity, 2 Mbps BLE ideal transmitter, packet length ≤ 37 bytes		-92		dBm
P _{SENS,IT,BLE 125k}	Sensitivity, 125 kbps BLE mode		-103		dBm
P _{SENS,IT,BLE 500k}	Sensitivity, 500 kbps BLE mode		-98		dBm
P _{SENS,IEEE 802.15.4}	Sensitivity in IEEE 802.15.4 mode		-100		dBm

1. Typical sensitivity applies when ADDR0 is used for receiver address correlation. When ADDR [1...7] are used for receiver address correlation, the typical sensitivity for this mode is degraded by 3dB.

2. Same as remark 1.

3. As defined in the Bluetooth Core Specification v4.0 Volume 6: Core System Package (Low Energy Controller Volume).

4. Equivalent BER limit < 10E-04.

5.3.7. RX Selectivity

Symbol	Description	Min.	Typ.	Max.	Units
C/I _{1M,co-channel}	1Mbps mode, Co-Channel interference		10		dB
C/I _{1M,-1MHz}	1 Mbps mode, Adjacent (-1 MHz) interference		-5		dB
C/I _{1M,+1MHz}	1 Mbps mode, Adjacent (+1 MHz) interference		-14		dB
C/I _{1M,-2MHz}	1 Mbps mode, Adjacent (-2 MHz) interference		-19		dB
C/I _{1M,+2MHz}	1 Mbps mode, Adjacent (+2 MHz) interference		-42		dB
C/I _{1M,-3MHz}	1 Mbps mode, Adjacent (-3 MHz) interference		-37		dB
C/I _{1M,+3MHz}	1 Mbps mode, Adjacent (+3 MHz) interference		-47		dB
C/I _{1M,±6MHz}	1 Mbps mode, Adjacent (≥6 MHz) interference		-52		dB
C/I _{1MBLE,co-channel}	1 Mbps BLE mode, Co-Channel interference		6		dB
C/I _{1MBLE,-1MHz}	1 Mbps BLE mode, Adjacent (-1 MHz) interference		-2		dB
C/I _{1MBLE,+1MHz}	1 Mbps BLE mode, Adjacent (+1 MHz) interference		-10		dB
C/I _{1MBLE,-2MHz}	1 Mbps BLE mode, Adjacent (-2 MHz) interference		-23		dB
C/I _{1MBLE,+2MHz}	1 Mbps BLE mode, Adjacent (+2 MHz) interference		-45		dB
C/I _{1MBLE,>3MHz}	1 Mbps BLE mode, Adjacent (≥3 MHz) interference		-54		dB
C/I _{1MBLE,image}	Image frequency interference		-24		dB
C/I _{1MBLE,image,1MHz}	Adjacent (1 MHz) interference to in-band image frequency		-37		dB

Symbol	Description	Min.	Typ.	Max.	Units
C/I _{2M,co-channel}	2 Mbps mode, Co-Channel interference		10		dB
C/I _{2M,-2MHz}	2 Mbps mode, Adjacent (-2 MHz) interference		-4		dB
C/I _{2M,+2MHz}	2 Mbps mode, Adjacent (+2 MHz) interference		-16		dB
C/I _{2M,-4MHz}	2 Mbps mode, Adjacent (-4 MHz) interference		-19		dB
C/I _{2M,+4MHz}	2 Mbps mode, Adjacent (+4 MHz) interference		-46		dB
C/I _{2M,-6MHz}	2 Mbps mode, Adjacent (-6 MHz) interference		-41		dB
C/I _{2M,+6MHz}	2 Mbps mode, Adjacent (+6 MHz) interference		-48		dB
C/I _{2M,≥12MHz}	2 Mbps mode, Adjacent (≥12 MHz) interference		-52		dB
C/I _{2MBLE,co-channel}	2 Mbps BLE mode, Co-Channel interference		7		dB
C/I _{2MBLE,-2MHz}	2 Mbps BLE mode, Adjacent (-2 MHz) interference		-2		dB
C/I _{2MBLE,+2MHz}	2 Mbps BLE mode, Adjacent (+2 MHz) interference		-12		dB
C/I _{2MBLE,-4MHz}	2 Mbps BLE mode, Adjacent (-4 MHz) interference		-22		dB
C/I _{2MBLE,+4MHz}	2 Mbps BLE mode, Adjacent (+4 MHz) interference		-46		dB
C/I _{2MBLE,≥6MHz}	2 Mbps BLE mode, Adjacent (≥6 MHz) interference		-52		dB
C/I _{2MBLE,image}	Image frequency interference		-22		dB
C/I _{2MBLE,image,2MHz}	Adjacent (2 MHz) interference to in-band image frequency		-37		dB
C/I _{125k BLE LR,co-channel}	125 kbps BLE LR mode, Co-Channel interference		3		dB
C/I _{125k BLE LR,-1MHz}	125 kbps BLE LR mode, Adjacent (-1 MHz) interference		-9		dB
C/I _{125k BLE LR,+1MHz}	125 kbps BLE LR mode, Adjacent (+1 MHz) interference		-16		dB
C/I _{125k BLE LR,-2MHz}	125 kbps BLE LR mode, Adjacent (-2 MHz) interference		-27		dB
C/I _{125k BLE LR,+2MHz}	125 kbps BLE LR mode, Adjacent (+2 MHz) interference		-54		dB
C/I _{125k BLE LR,>3MHz}	125 kbps BLE LR mode, Adjacent (≥3 MHz) interference		-60		dB
C/I _{125k BLE LR,image}	Image frequency interference		-27		dB
C/I _{IEEE 802.15.4,-5MHz}	IEEE 802.15.4 mode, Adjacent (-5 MHz) rejection		-33		dB
C/I _{IEEE 802.15.4,+5MHz}	IEEE 802.15.4 mode, Adjacent (+5 MHz) rejection		-38		dB
C/I _{IEEE 802.15.4,±10MHz}	IEEE 802.15.4 mode, Alternate (±10 MHz) rejection		-49		dB

Remark: Desired signal level at PIN = -67 dBm. One interferer is used, having equal modulation as the desired signal. The input power of the interferer where the sensitivity equals BER = 0.1% is

5.3.8. RX Intermodulation

Symbol	Description	Min.	Typ.	Max.	Units
P _{IMD,5TH,1M}	IMD performance, 1 Mbps, 5th offset channel, packet length ≤ 37 bytes		-34		dBm
P _{IMD,5TH,1M,BLE}	IMD performance, BLE 1 Mbps, 5th offset channel, packet length ≤ 37 bytes		-32		dBm
P _{IMD,5TH,2M}	IMD performance, 2 Mbps, 5th offset channel, packet length ≤ 37 bytes		-33		dBm
P _{IMD,5TH,2M,BLE}	IMD performance, BLE 2 Mbps, 5th offset channel, packet length ≤ 37 bytes		-32		dBm

Remark: Desired signal level at PIN = -64 dBm. Two interferers with equal input power are used. The interferer closest in frequency is not modulated, the other interferer is modulated equal with the desired signal. The input power of the interferers where the sensitivity equals BER = 0.1% is presented.

5.3.9. Radio Timing Parameters

Symbol	Description	Min.	Typ.	Max.	Units
t _{TXEN,BLE,1M}	Time between TXEN task and READY event after channel FREQUENCY configured (1 Mbps BLE and 150 μs TIFS)	140		140	μs
t _{TXEN,FAST,BLE,1M}	Time between TXEN task and READY event after channel FREQUENCY configured (1 Mbps BLE with fast ramp-up and 150 μs TIFS)	40		40	μs
t _{TXDIS,BLE,1M}	When in TX, delay between DISABLE task and DISABLED event for MODE = Nrf_1Mbit and MODE = Ble_1Mbit	6		6	μs
t _{RXEN,BLE,1M}	Time between the RXEN task and READY event after channel FREQUENCY configured (1 Mbps BLE)	140		140	μs
t _{RXEN,FAST,BLE,1M}	Time between the RXEN task and READY event after channel FREQUENCY configured (1 Mbps BLE with fast ramp-up)	40		40	μs
t _{RXDIS,BLE,1M}	When in RX, delay between DISABLE task and DISABLED event for MODE = Nrf_1Mbit and MODE = Ble_1Mbit	0		0	μs
t _{TXDIS,BLE,2M}	When in TX, delay between DISABLE task and DISABLED event for MODE = Nrf_2Mbit and MODE = Ble_2Mbit	4		4	μs
t _{RXDIS,BLE,2M}	When in RX, delay between DISABLE task and DISABLED event for MODE = Nrf_2Mbit and MODE = Ble_2Mbit	0		0	μs
t _{TXEN,IEEE 802.15.4}	Time between TXEN task and READY event after channel FREQUENCY configured (IEEE 802.15.4)	130		130	μs
t _{TXEN,FAST,IEEE 802.15.4}	Time between TXEN task and READY event after channel FREQUENCY configured (IEEE 802.15.4 with fast ramp-up)	40		40	μs
t _{TXDIS,IEEE 802.15.4}	When in TX, delay between DISABLE task and DISABLED event (IEEE 802.15.4)	21		21	μs
t _{RXEN,IEEE 802.15.4}	Time between the RXEN task and READY event after channel FREQUENCY configured (IEEE 802.15.4)	130		130	μs
t _{RXEN,FAST,IEEE 802.15.4}	Time between the RXEN task and READY event after channel FREQUENCY configured (IEEE 802.15.4 with fast ramp-up)	40		40	μs
t _{RXDIS,IEEE 802.15.4}	When in RX, delay between DISABLE task and DISABLED event (IEEE 802.15.4)	0.5		0.5	μs
t _{RX-to-TX turnaround}	Maximum TX-to-RX or RX-to-TX turnaround time in IEEE 802.15.4 mode		40		μs

5.3.10. CPU

Symbol	Description	Min.	Typ.	Max.	Units
W _{FLASH}	CPU wait states, running CoreMark from flash, cache disabled			2	
W _{FLASHCACHE}	CPU wait states, running CoreMark from flash, cache enabled			3	
W _{RAM}	CPU wait states, running CoreMark from RAM			0	
CM _{FLASH}	CoreMark, running CoreMark from flash, cache enabled		217		irk
CM _{FLASH/MHz}	CoreMark per MHz, running CoreMark from flash, cache enabled		3.4		CoreMark/MHz
CM _{FLASH/ma}	CoreMark per mA, running CoreMark from flash, cache enabled, DCDC 3V		65.8		CoreMark/mA

5.3.11. Power Management





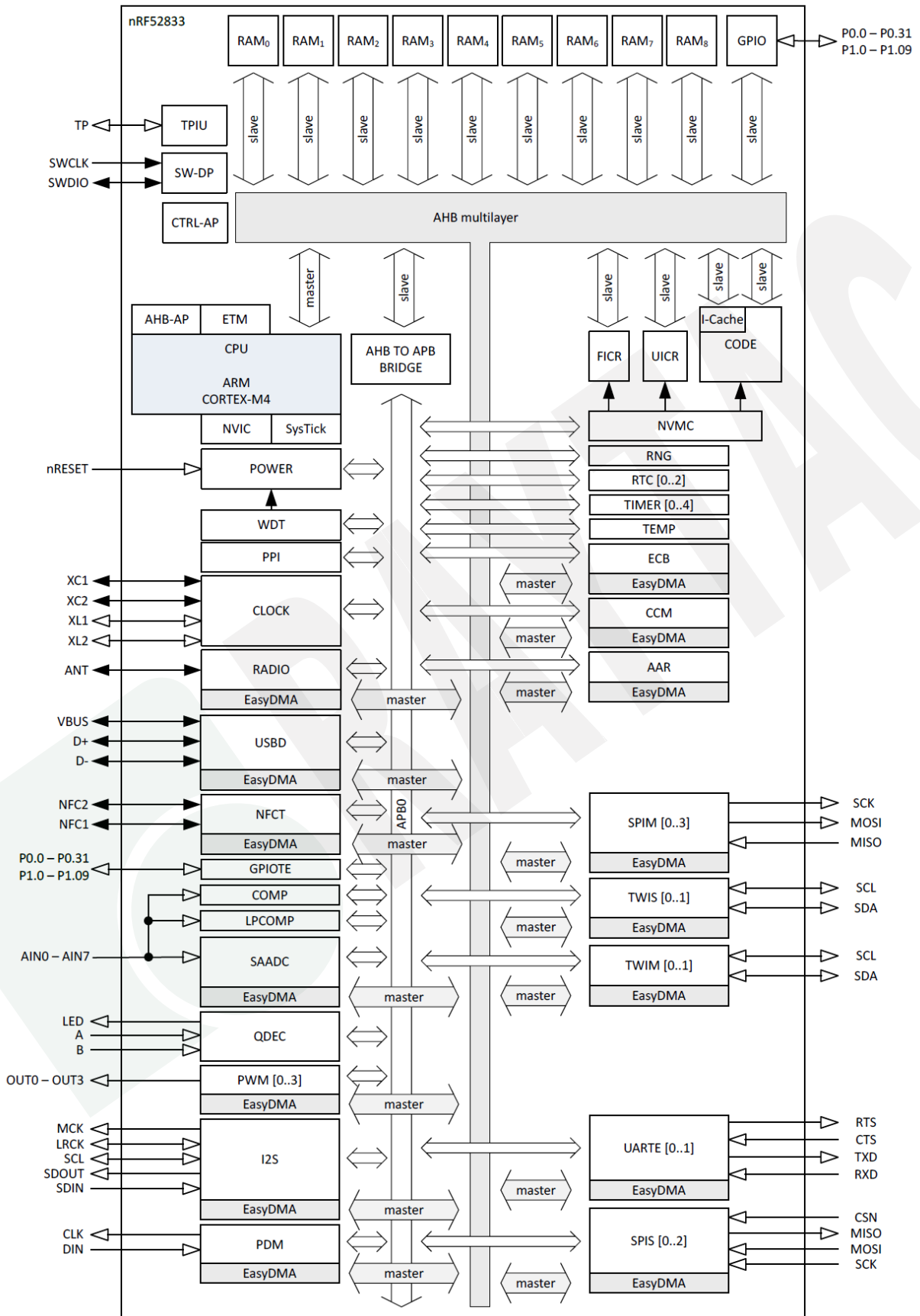



Symbol	Description	Min.	Typ.	Max.	Units
I _{ON_RAMOFF_EVENT}	System ON, no RAM retention, wake on any event		1.1		μA
I _{ON_RAMON_EVENT}	System ON, full 128 kB RAM retention, wake on any event		1.8		μA
I _{ON_RAMON_POF}	System ON, full 128 kB RAM retention, wake on any event, power-fail comparator enabled		1.9		μA
I _{ON_RAMON_GPIOTE}	System ON, full 128 kB RAM retention, wake on GPIOTE input (event mode)		7.4		μA
I _{ON_RAMON_GPIOTEPORT}	System ON, full 128 kB RAM retention, wake on GPIOTE PORT event		1.8		μA
I _{ON_RAMOFF_RTC}	System ON, no RAM retention, wake on RTC (running from LFRC clock)		1.5		μA
I _{ON_RAMON_RTC}	System ON, full 128 kB RAM retention, wake on RTC (running from LFRC clock)		2.6		μA
I _{OFF_RAMOFF_RESET}	System OFF, no RAM retention, wake on reset		0.6		μA
I _{OFF_RAMOFF_LPCOMP}	System OFF, no RAM retention, wake on LPCOMP		0.9		μA
I _{OFF_RAMON_RESET}	System OFF, full 128 kB RAM retention, wake on reset		1.3		μA
I _{ON_RAMOFF_EVENT_5V}	System ON, no RAM retention, wake on any event, 5 V supply on VDDH, REG0 output = 3.3 V		1.3		μA
I _{OFF_RAMOFF_RESET_5V}	System OFF, no RAM retention, wake on reset, 5 V supply on VDDH, REG0 output = 3.3 V		1.0		μA

6. Block Diagram



7. Antenna

Below chart shows a few options of external antenna which has been tested and approved to use with MDBT50Q-U. Please check [9. Certification](#) for more details.

#	Photo	Model No.	Type	Supplier	Gain	Spec	Certification
1		ANTX100 ETHAB24553	External	Yageo	≤ 2 dBi		FCC, IC, TELEC KC, NCC, CE SRRC, RCM
2		RFA-02-5 -F17H170100B	External	Aristotle	5 dBi		FCC, IC, KC NCC, SRRC
3		ANTX100 P011B24003	PCB	Yageo	2.2 dBi		FCC, IC, TELEC KC, NCC, CE SRRC, RCM
4		ANTX100 P111B24003	PCB	Yageo	3.3 dBi		FCC, IC, TELEC KC, NC, SRRC

** End-product may need to perform further testing when applying CE, RCM and SRRC. Others are modular approval.*

** Our certificate(s) might not be applicable when using antenna apart from above list.*

8. Reference Circuit

This chapter shows a different combination of reference circuits. **Before getting started, please read below notes carefully because it is applied to all the reference circuits.**

- 32MHz crystal and RF (VDD) DC/DC inductor (Reg1) are already inside the module.
- Module is pre-programmed with Raytac testing code. Default is using LDO mode and need to add external 32.768khz to work.

You can use DC-DC mode *without* adding external 32.768khz, they are **NOT** related events.

- When using internal 32.768khz RC oscillator, please remove X2 / C12 / C13.
- When **NOT** using NFC, please remove NFC1 / C19 / C21.

8.1. Reg0 LDO Mode

Recommend using when *the highest* input voltage is equal or greater than 3.6V. Supply power from VDDH.

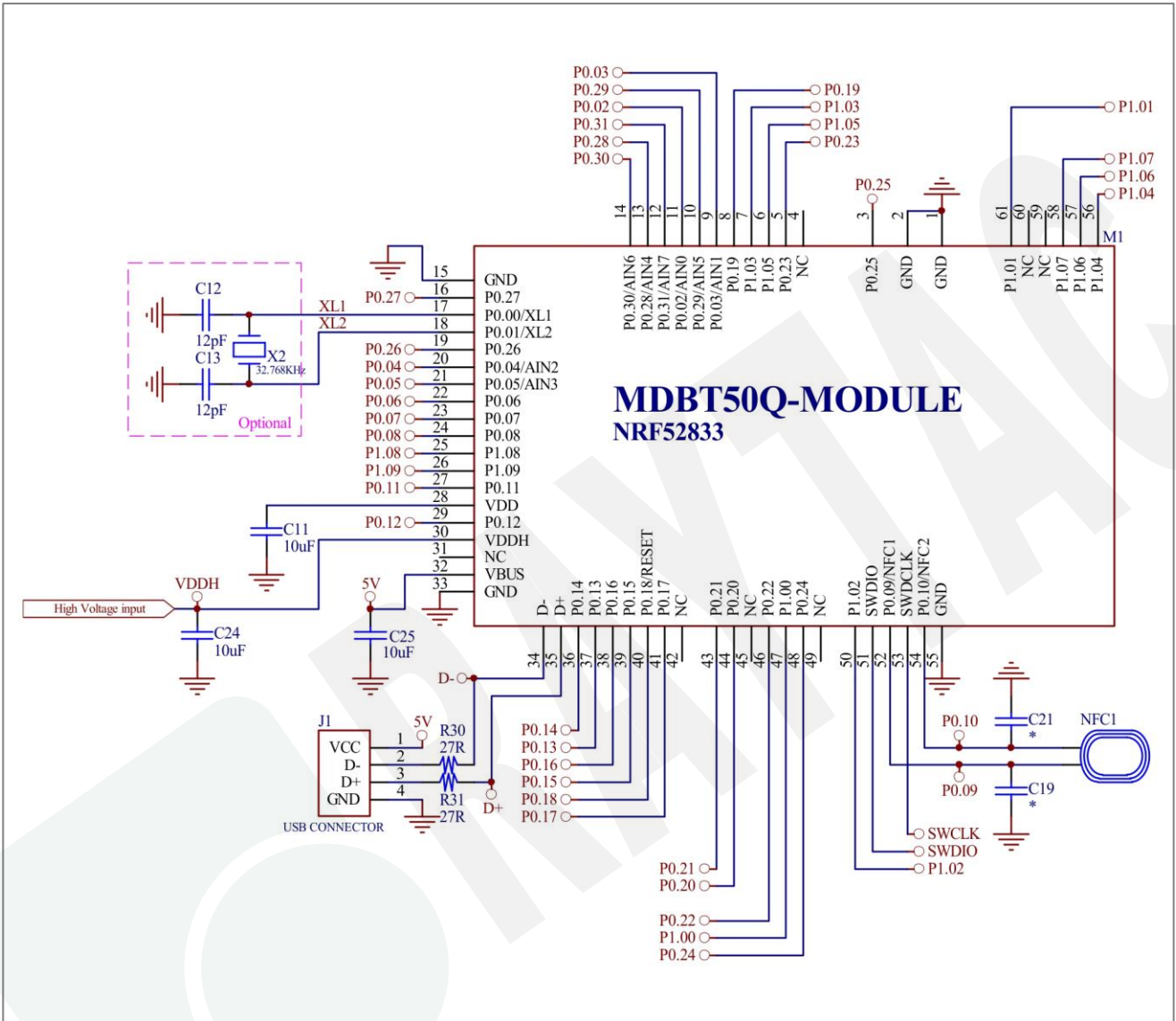

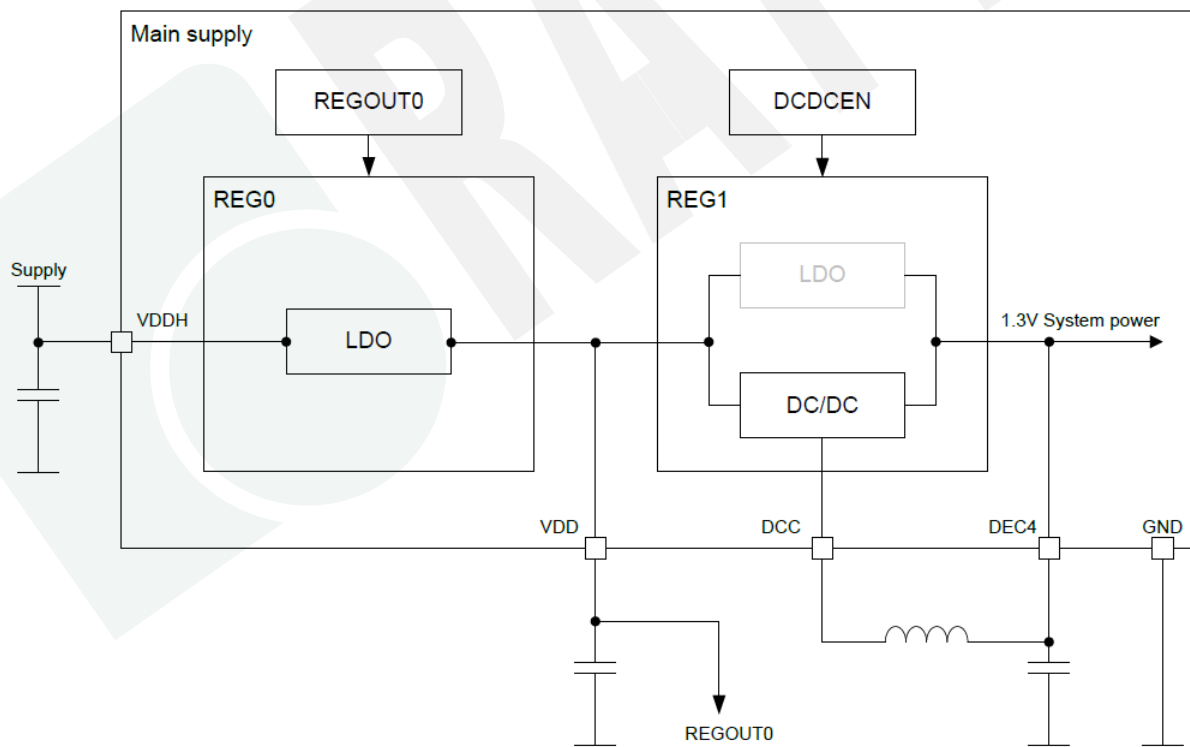
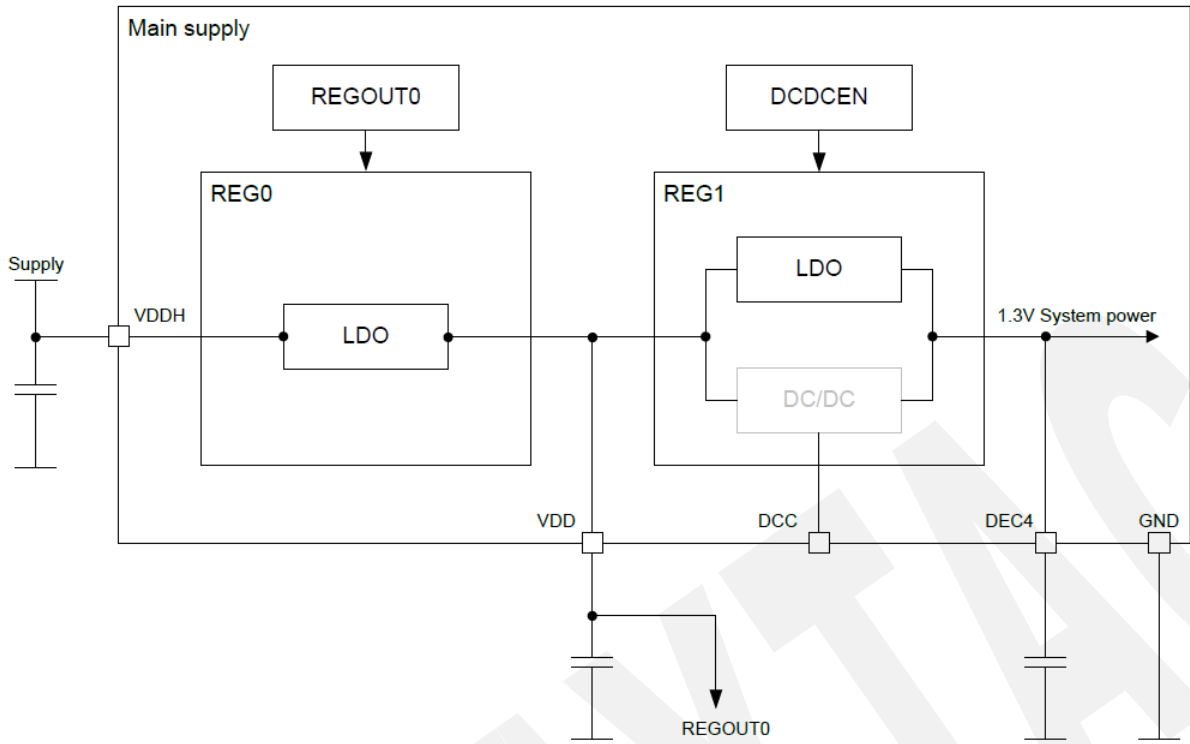

8.2. Reg0 LDO Mode Disabled

Recommend using when *the highest* input voltage is less than 3.6V.

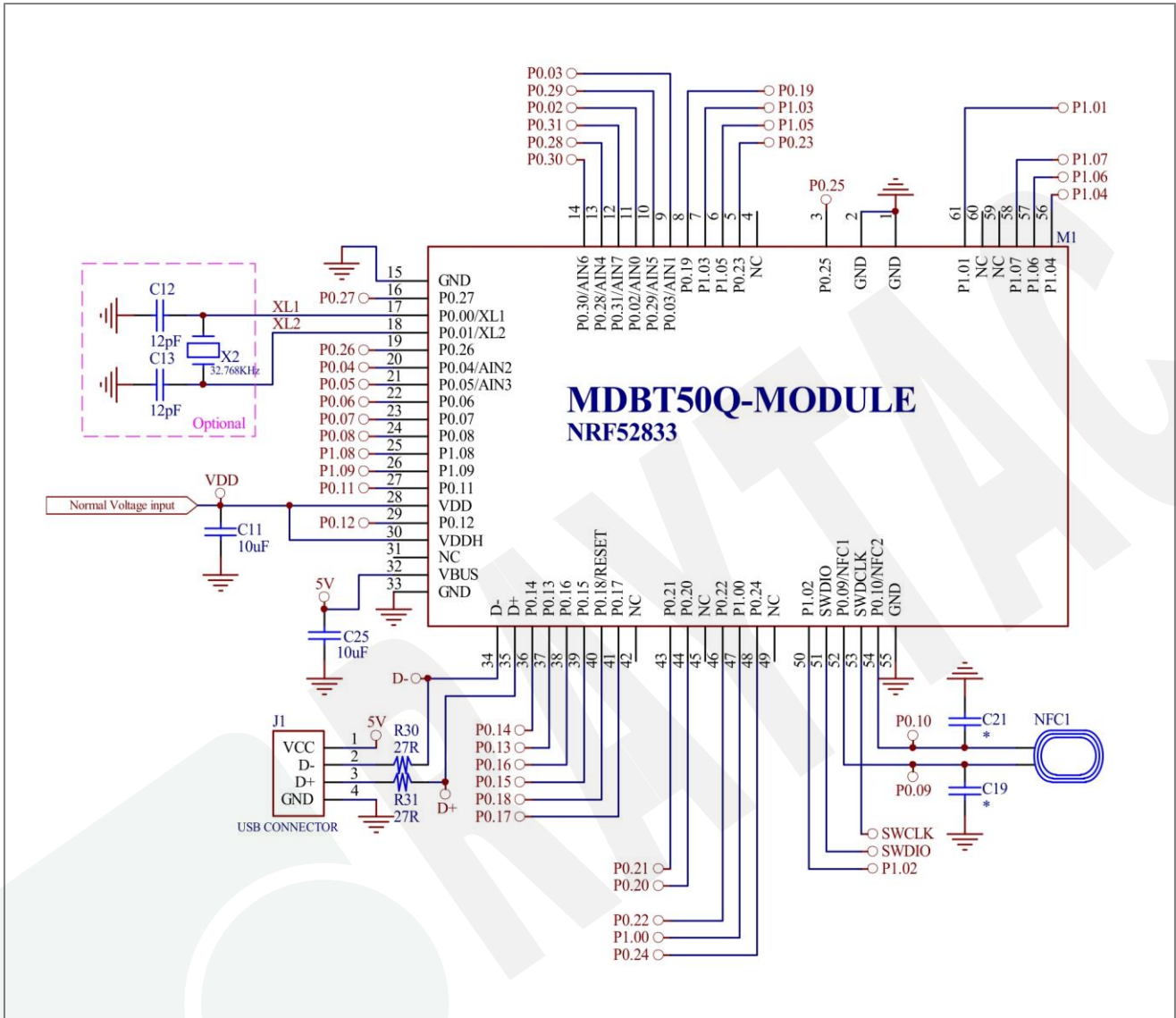

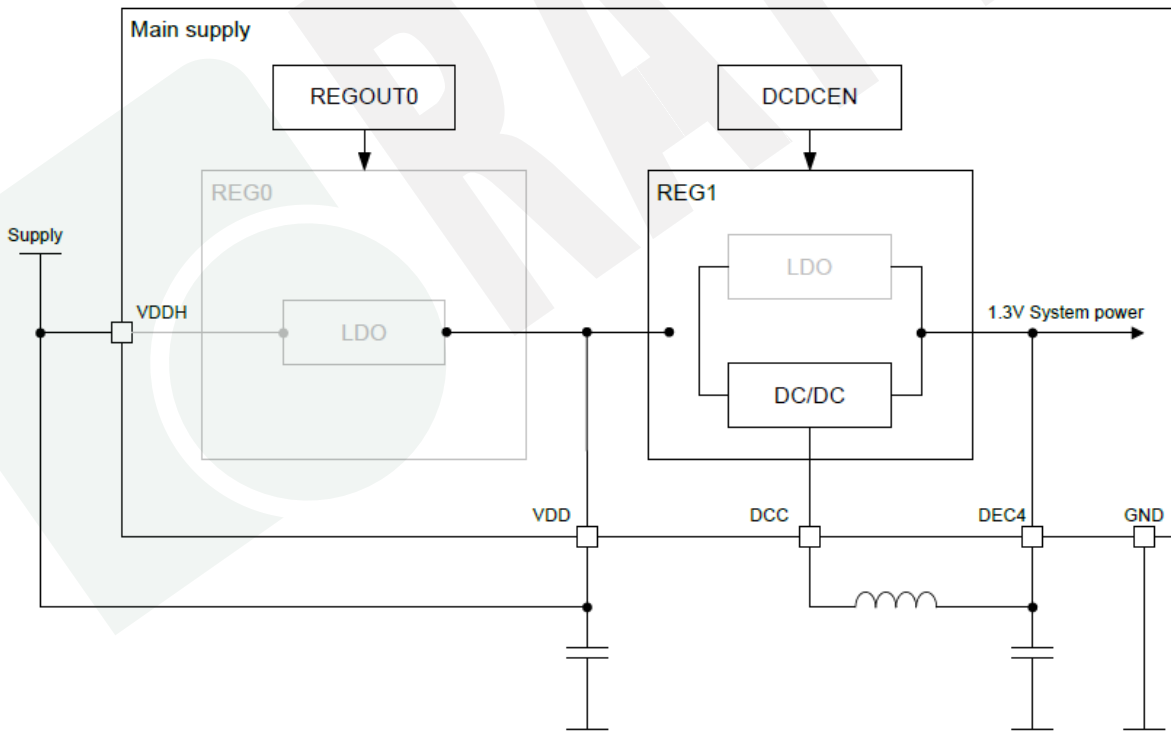
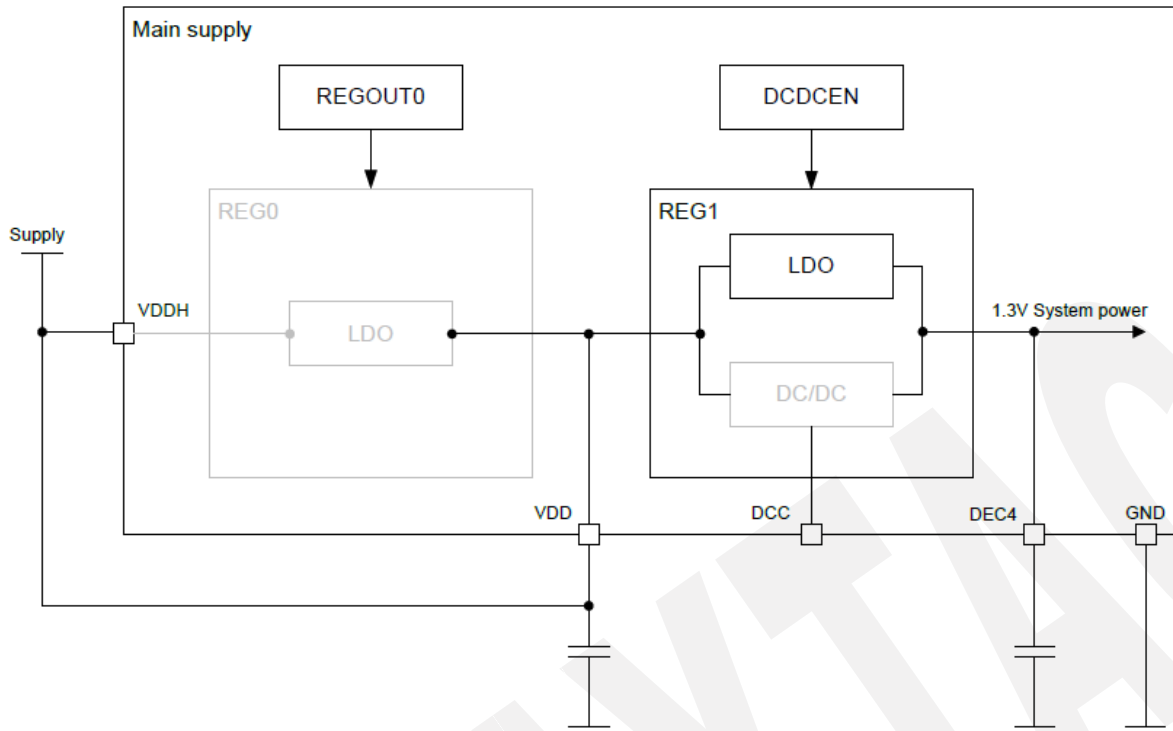

8.3. USB Powered

Recommend using when power the device via USB.

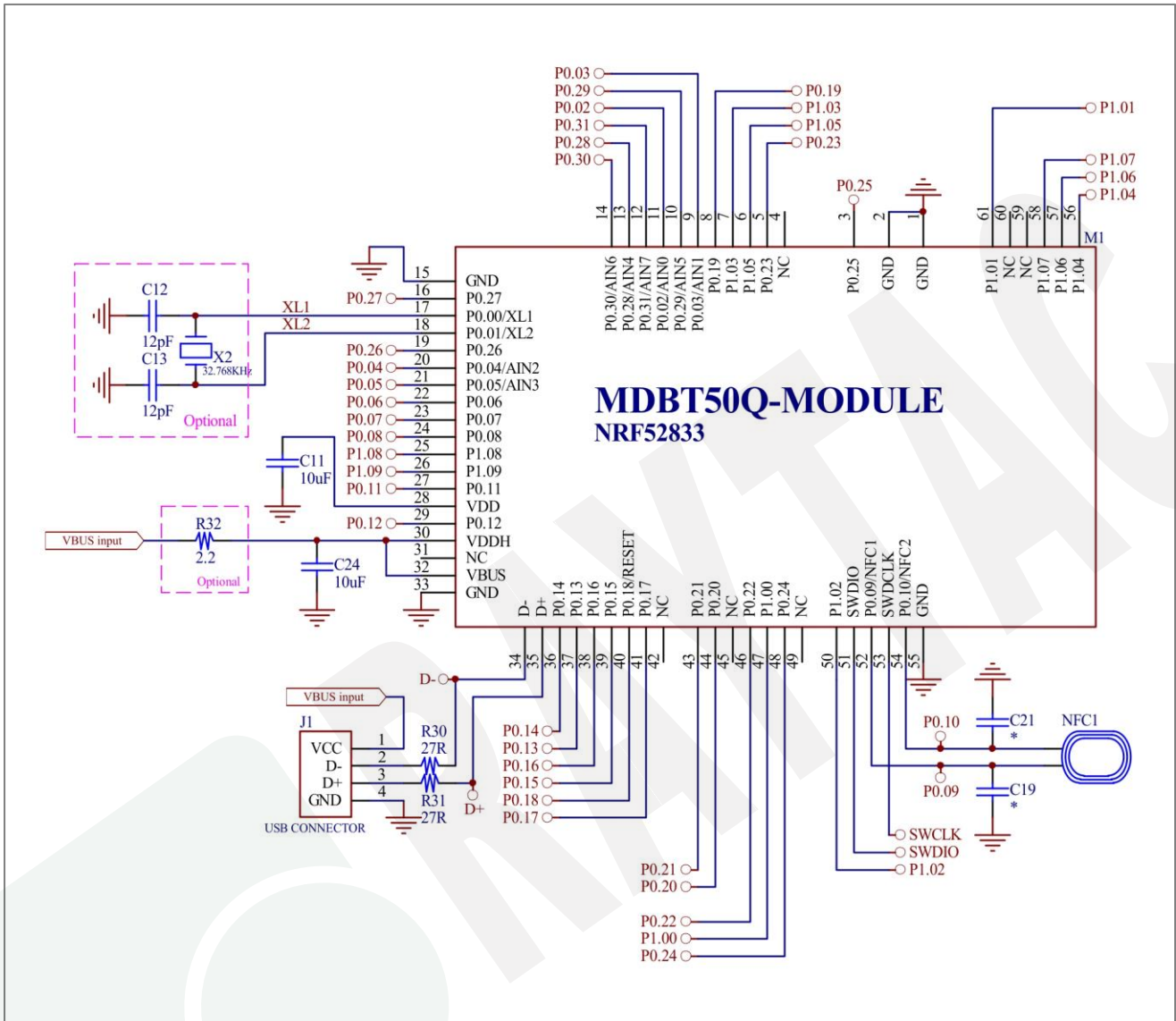

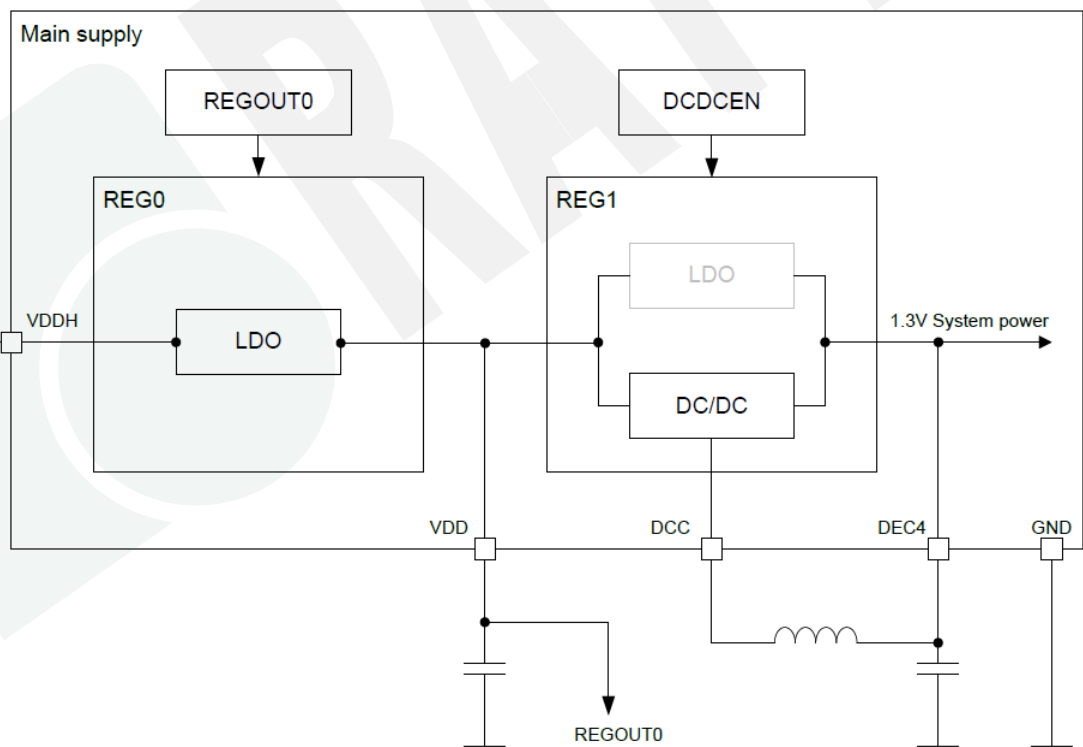
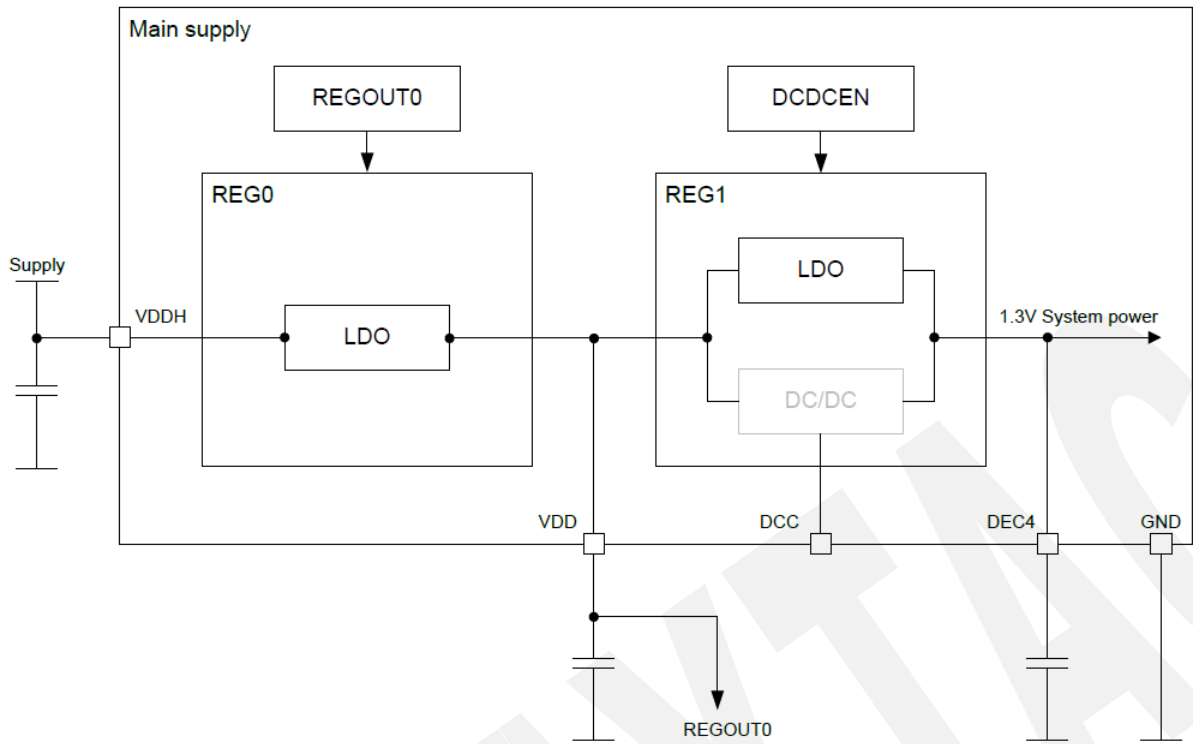

8.4. USB Disabled

This circuit only focuses on USB disabled. **Please leave D+ & D- as NC when USB is disabled.**

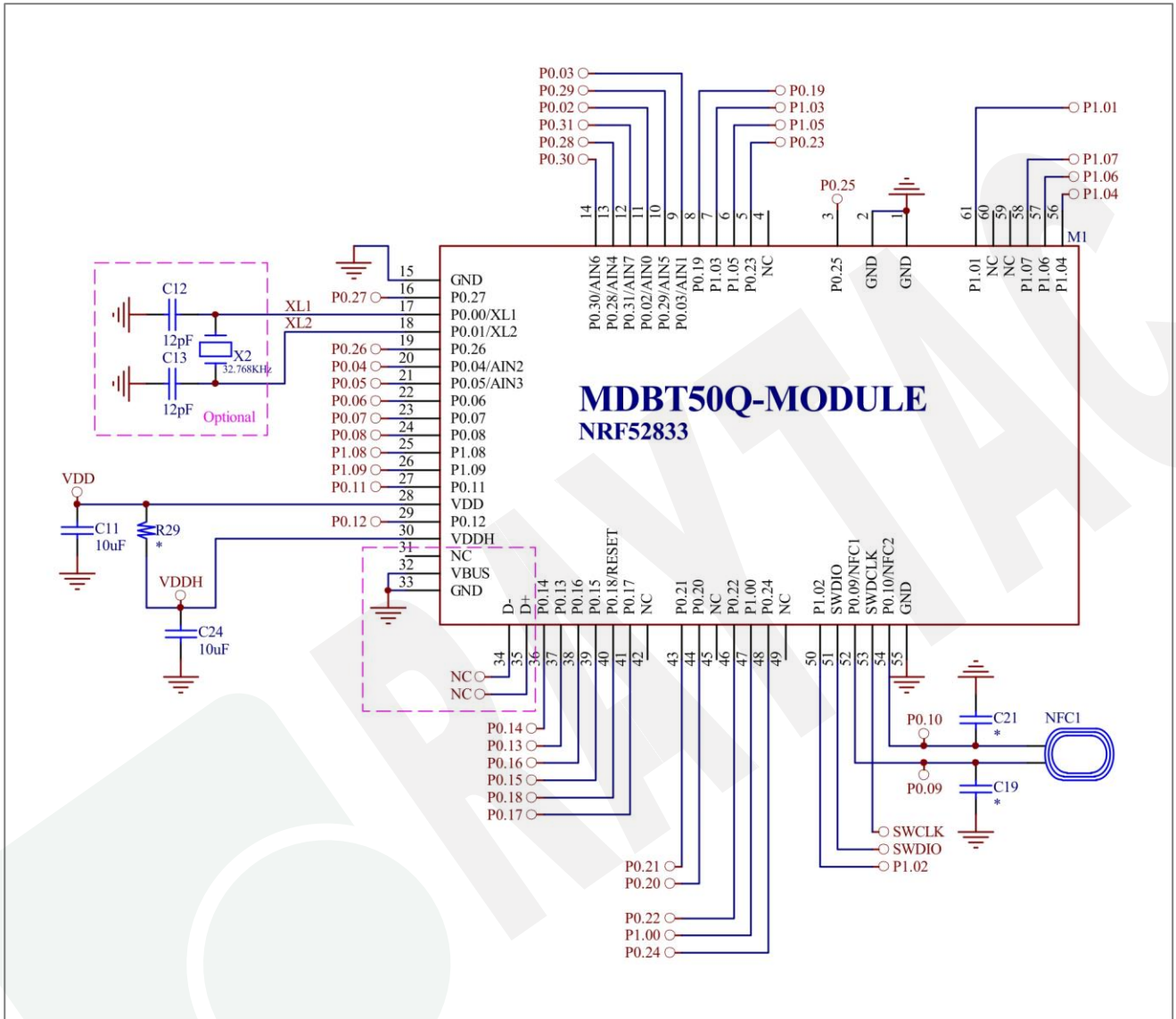

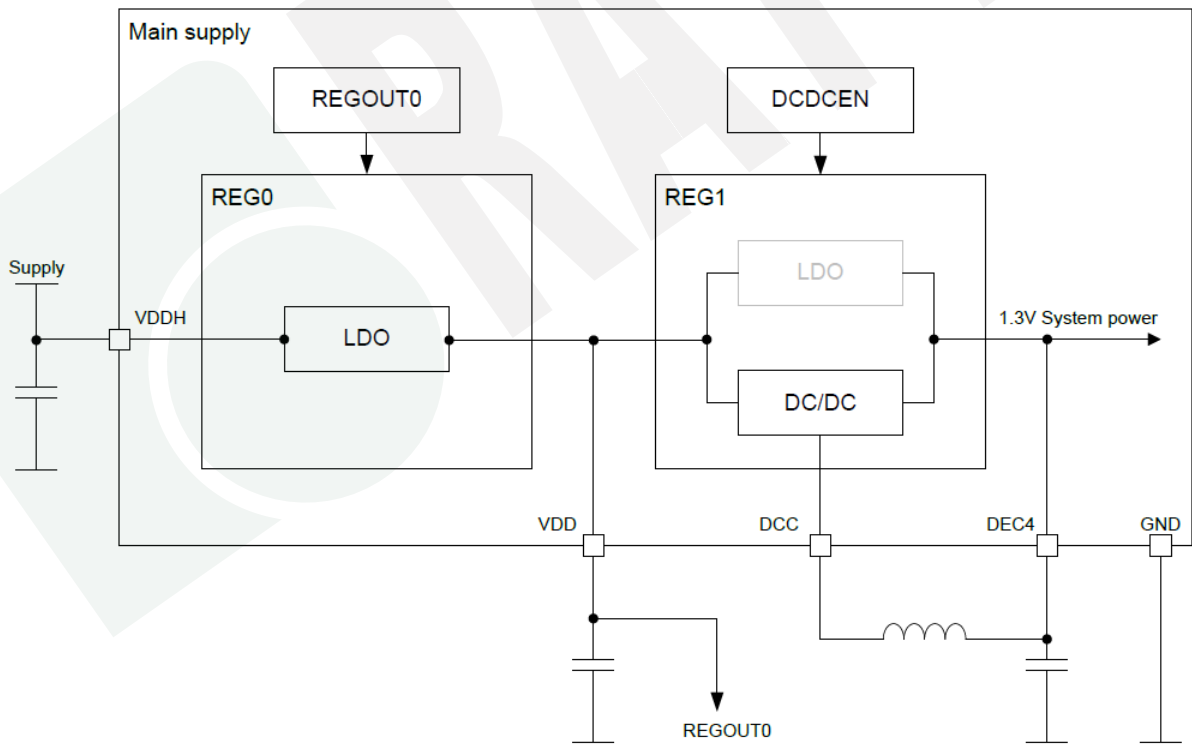
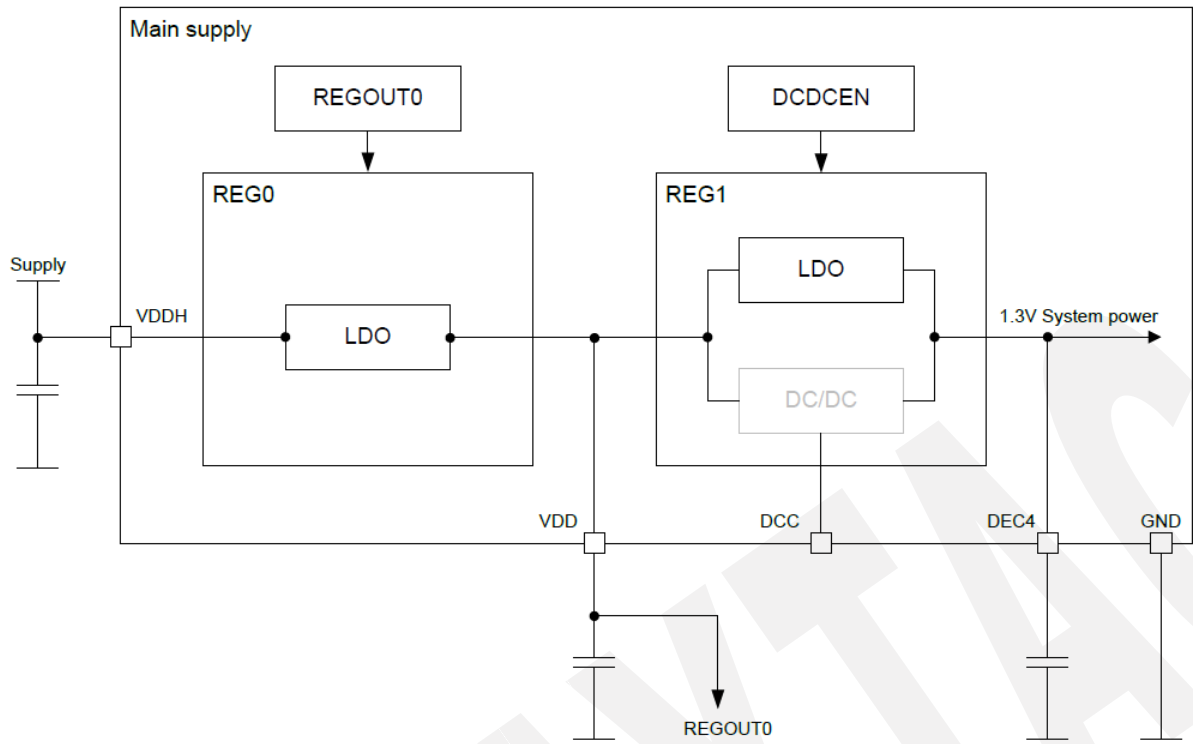

9. Certification

9.1. Declaration ID

BT 5.1

Declaration ID	QDID(s)	Company	Specification Name
D047708	139361 - End Product	Raytac Corporation	5.1

BT 5.2

Declaration ID	QDID(s)	Company	Specification Name
D053149	159932 - End Product	Raytac Corporation	5.2

Profile Description	Service Description
Alert Notification Profile	Alert Notification Service
Blood Pressure Profile	Blood Pressure Service
	Device Information Service
Cycling Speed & Cadence Profile	Cycling Speed & Cadence Service
	Device Information Service
Glucose Profile	Glucose Service
	Device Information Service
Health Thermometer Profile	Health Thermometer Service
	Device Information Service
Heart Rate Profile	Heart Rate Service
	Device Information Service
HID over GATT Profile	HID Service
	Battery Service
Proximity Profile	Link Loss Service
	Immediate Alert Service
	TX Power Service
Running Speed & Cadence Profile	Running Speed & Cadence Service
	Device Information Service
Time Profile	Time Profile Service
Glucose Profile (Central)	
Mesh Profile	Mesh Provisioning Service
	Mesh Proxy Service

9.2. FCC Certificate (USA)

BLE 1Mbps & 2Mbps, IEEE 802.15.4 approved.



TCB

**GRANT OF EQUIPMENT
AUTHORIZATION**
Certification
Issued Under the Authority of the
Federal Communications Commission
By:

TCB

Raytac Corp.
5F., No.3, Jiankang Rd., Zhonghe Dist.,
New Taipei City,, 23586
Taiwan

Attention: Venson Liao , R&D Manager

Telefication B.V.
Edisonstraat 12a
Zevenaar, NL-6902 PK
Netherlands

Date of Grant: 07/26/2018

Application
Dated: 07/25/2018

NOT TRANSFERABLE

EQUIPMENT AUTHORIZATION is hereby issued to the named GRANTEE, and is VALID ONLY for the equipment identified hereon for use under the Commission's Rules and Regulations listed below.

FCC IDENTIFIER:	SH6MDBT50Q			
Name of Grantee:	Raytac Corp.			
Equipment Class:	Digital Transmission System			
Notes:	Bluetooth Low Energy & IEEE 802.15.4 Combo Module			
Modular Type:	Single Modular			





Grant Notes	FCC Rule Parts	Frequency Range (MHZ)	Output Watts	Frequency Tolerance	Emission Designator
	15C	2402.0 - 2480.0	0.0066		
	15C	2405.0 - 2480.0	0.0066		

Modular Approval. This is a portable device. Power Output is conducted. This grant is valid only when the module is sold to OEM integrators and must be installed by the OEM or OEM integrators. End-users may not be provided with the module installation instructions. OEM integrators and end-users must be provided with transmitter operating conditions for satisfying RF exposure compliance.

Certificate No.: 182180940/AA/00	Ramy Nabod Product Assessor	
-------------------------------------	--------------------------------	--

9.3. TELEC Certificate (Japan)

BLE 1 Mbps & 2 Mbps

	<i>Certificate Technical Support Center Co., Ltd.</i> RAB ID No. 018
Construction Type Certification	
Registration No.	CSRT180280-1
Certificate Holder	Raytac Corporation 5F, No.3, Jiankang Rd., Zhonghe Dist., New Taipei City, 235, Taiwan
Product Category	Article 2, Paragraph 1, Item 19
Model Type or Name	MDBT50Q, MDBT50Q-1M, MDBT50Q-P1M, MDBT50Q-U1M, MDBT50Q-P, MDBT50Q-U
Type of Emission, Frequency and Antenna Power	F1D 2402MHz - 2480MHz (2MHz separation, 40 channels) 5.9704mW, 5.0816mW
Manufacturer	Raytac Corporation 5F, No.3, Jiankang Rd., Zhonghe Dist., New Taipei City, 235, Taiwan
Factory	Tech-Lin's Electronics Corp. 5F/11F, No. 778, Zhongzheng Rd., Zhonghe Dist., New Taipei City 23586, Taiwan R.O.C
Remarks	The scope of evaluation relates to the submitted documents and product only. It is only valid in conjunction with the Annex.
When the product is placed on the Japanese market, the Specified Radio Equipment marking as shown on the right must be attached on visible part of the product.	 R 018-180280
Witnesses that the certification is on Construction Type Certification under Article 38-24 of the Radio Law.	
Date of Certificate 2018/7/30	 Certification Examiner : Takuji Nakano  C&S Certificate Technical Support Center Co., Ltd.
Address: 610- 1 Kishine-cho, Kohoku-ku, Yokohama-City, 222-0034 Japan Tel.: +81 45 594 9185 • Fax: +81 45 594 9183 • E-mail: cert@cns-web.co.jp	

IEEE 802.15.4



Certificate Technical Support Center Co.,Ltd.
RAB ID No. 018

Construction Type Certification

Registration No.	CSRT180280-1
Certificate Holder	Raytac Corporation 5F, No.3, Jiankang Rd., Zhonghe Dist., New Taipei City, 235, Taiwan
Product Category	Article 2, Paragraph 1, Item 19
Model Type or Name	MDBT50Q, MDBT50Q-1M, MDBT50Q-P1M, MDBT50Q-U1M, MDBT50Q-P, MDBT50Q-U
Type of Emission, Frequency and Antenna Power	G1D 2405MHz - 2480MHz (5MHz separation, 16 channels) 3.539mW/MHz
Manufacturer	Raytac Corporation 5F, No.3, Jiankang Rd., Zhonghe Dist., New Taipei City, 235, Taiwan
Factory	Tech-Lin's Electronics Corp. 5F/11F, No. 778, Zhongzheng Rd., Zhonghe Dist., New Taipei City 23586, Taiwan R.O.C
Remarks	The scope of evaluation relates to the submitted documents and product only. It is only valid in conjunction with the Annex.

When the product is placed on the Japanese market, the Specified Radio Equipment marking as shown on the right must be attached on visible part of the product.



R 018-180280

Witnesses that the certification is on Construction Type Certification under Article 38-24 of the Radio Law.

Date of Certificate
2018/7/30

Takuji Nakano

Certification Examiner : Takuji Nakano
C&S Certificate Technical Support Center Co., Ltd.





Address: 610-1 Kishine-cho, Kohoku-ku, Yokohama-City, 222-0034 Japan
Tel.: +81 45 594 9185 • Fax: +81 45 594 9183 • E-mail: cert@cns-web.co.jp

9.4. NCC Certificate (Taiwan)

BLE 1Mbps & 2Mbps, IEEE 802.15.4 approved.

MDBT50Q-U

	台灣檢驗科技股份有限公司 電信管制射頻器材型式認證證明
一、申請者：	勁達國際電子有限公司
二、地址：	臺北市大安區和平東路1段145號5樓之1
三、製造廠商：	勁達國際電子有限公司
四、器材名稱：	低功耗藍牙及 IEEE 802.15.4 整合模組
五、廠牌：	Raytac
六、型號：	MDBT50Q-U
七、發射功率(電場強度)：	詳細射頻規格如備註欄
八、工作頻率：	詳細射頻規格如備註欄
九、審驗日期：	108年10月24日
十、審驗合格標籤式樣：	
十一、警語或標示要求：	(器材本體、使用手冊、外包裝盒等應遵守下列標示要求)
1.	應依審驗合格標籤或符合性聲明標籤式樣自製標籤黏貼或印鑄於電信管制射頻器材本體明顯處，並於包裝盒標示本會標章，始得開陳列或販賣。
2.	電信管制射頻器材應依本會或相關技術規範規定於指定位置標示中文警語。
3.	經授權使用射頻模組(組件)之審驗合格標籤者，應於最終產品說明書及包裝盒提供充分與正確之資訊。
4.	於網際網路販賣取得審驗證明之電信管制射頻器材者，應於該網際網路網頁提供審驗合格標籤或符合性聲明標籤資訊。
5.	使用手冊應標示下列資訊： (1)經型式認證合格之低功率射頻電機，非經許可，公司、商號或使用者均不得擅自變更頻率、加大功率或變更原設計之特性及功能。低功率射頻電機之使用不得影響飛航安全及干擾合法通信；經發現有干擾現象時，應立即停用，並改善至無干擾時方得繼續使用。前項合法通信，指依電信法規定作業之無線電通信。低功率射頻電機須忍受合法通信或工業、科學及醫療用電波輻射性電機設備之干擾。
6.	本器材之審驗範圍僅限無線射頻硬體功能，不及於器材之資通安全檢測。

型式認證號碼：CCAM18LP0825T4 第 1 頁，共 2 頁 本證書與續頁分開使用無效

9.5. CE (EU) & RCM (Australia & New Zealand) Test Report

BLE 1 Mbps & 2 Mbps

	Report No.: E2/2018/50088-02 Page: 1 of 73
RED (2014/53/EU) ETSI EN 300 328 v2.2.2 : 2019 & Australian/New Zealand Standard AS/NZS 4268:2017 TEST REPORT	
FOR	
Applicant:	Raytac Corporation 5F, No.3, Jiankang Rd., Zhonghe Dist., New Taipei City, 235, Taiwan
Product Name:	Bluetooth Low Energy & IEEE 802.15.4 Combo Module
Brand Name:	Raytac
Model No.:	MDBT50Q, MDBT50Q-P, MDBT50Q-U
Model Difference:	Different Antenna Type
Report Number:	E2/2018/50088-02
Issue Date:	Jun. 15, 2020
Date of Test:	May 31, 2018 ~ Jun. 28, 2018 (Original test), Jun. 05, 2020 (Update receiver blocking)
Date of EUT Received:	May 31, 2018 (Original test), Apr. 16, 2020 (Update receiver blocking)
We hereby certify that: The above equipment was tested by SGS Taiwan Ltd., Central RF Lab for compliance with the requirements set forth in the European Standard ETSI EN 300 328 v2.2.2: 2019 under RED 2014/53/EU and Australian/New Zealand Standard AS/NZS 4268:2017, Row 59. Test report to determine compliance with AS/NZS 4268 requirements. The results of testing in this report apply to the product system that was tested only. Other similar equipment will not necessarily produce the same results due to production tolerance and measurement uncertainties.	
Approved By:	 <u>Jay Lin / Asst. Supervisor</u>
	 



RED (2014/53/EU) ETSI EN 300 328 v2.2.2 : 2019
&
Australian/New Zealand Standard AS/NZS 4268:2017
TEST REPORT

FOR

Applicant: Raytac Corporation
5F, No.3, Jiankang Rd., Zhonghe Dist., New Taipei City, 235,
Taiwan
Product Name: Bluetooth Low Energy & IEEE 802.15.4 Combo Module
Brand Name: Raytac
Model No.: MDBT50Q, MDBT50Q-P, MDBT50Q-U
Model Difference: Different Antenna Type
Report Number: E2/2018/50089-02
Issue Date: Jun. 11, 2020
Date of Test: May 31, 2018 ~ Jul. 23, 2018 (Original test),
Jun. 08, 2020 (Update receiver blocking)
Date of EUT Received: May 31, 2018 (Original test),
Apr. 16, 2020 (Update receiver blocking)

We hereby certify that:

The above equipment was tested by SGS Taiwan Ltd., Central RF Lab for compliance with the requirements set forth in the European Standard ETSI EN 300 328 v2.2.2: 2019 under RED 2014/53/EU and Australian/New Zealand Standard AS/NZS 4268:2017. Test report to determine compliance with AS/NZS 4268 requirements. The results of testing in this report apply to the product system that was tested only. Other similar equipment will not necessarily produce the same results due to production tolerance and measurement uncertainties.

Approved By:

Jay Lin

Jay Lin / Asst. Supervisor





SGS Reference No: MH/2018/60113C-01

VERIFICATION OF EMC COMPLIANCE

Verification No. : MH/2018/60113C-01
Representative Model No. : MDBT50Q
Added Model(s) : MDBT50Q-P, MDBT50Q-U
Product Name : Bluetooth Low Energy & IEEE 802.15.4 Combo Module
Brand Name : Raytac
Applicant : Raytac Corporation
Address of Applicant : 5F, No.3, Jiankang Rd., Zhonghe Dist., New Taipei City, 235, Taiwan
Test Report Number : MH/2018/60113-01
Date of Issue : Oct. 02, 2019
Applicable Standards : EN 301 489 -1 v2.2.0 : 2017-03 (Draft)
EN 301 489 -17 v3.2.0 : 2017-03 (Draft)
EN 55032 : 2015+AC:2016-07
EN 61000-4-2 : 2009, EN 61000-4-3 : 2006+A1:2008+A2:2010

Conclusion

Please be noted that the VERIFICATION MH/2018/60113C-01 will replace the previous MH/2018/60113C as the new version. Also be pay attention that MH/2018/60113C is ineffective anymore from now on.

The apparatus meets the requirements of the above standards and hence compliance the essential requirements under article 3.1b of the RED (2014/53/EU) Directive.

*This verification is only valid for the equipment and configuration described, and in conjunction with the test report as detailed above.

Authorized Signatory:

SGS TAIWAN LTD.
Eddy Cheng
Technical Asst. Supervisor

9.6. IC Certificate (Canada)

BLE 1Mbps & 2Mbps, IEEE 802.15.4 approved.

<p>telefication bv The Netherlands Chamber of Commerce 51565536 www.telefication.com</p>				
<p>TECHNICAL ACCEPTANCE CERTIFICATE</p>		<p>CERTIFICAT D'ACCEPTABILITÉ TECHNIQUE</p>		
CERTIFICATION No. No. DE CERTIFICATION	8017A-MDBT50QU			
TELEFICATION No. No. DE TELEFICATION	192170354/AA/00			
TEST SITE No. No. DE LABORATOIRE	4620A-5			
ISSUED TO DELIVRÉ A	Raytac Corporation			
TYPE OF EQUIPMENT GENRE DE MATÉRIEL	Bluetooth device Spread Spectrum/Digital Device (2400-2483.5 MHz)			
TRADE NAME AND MODEL MARQUE ET MODELE	Raytac / MDBT50Q-U1M Raytac / MDBT50Q-U			
CERTIFIED TO CERTIFIÉ SELON LE	SPECIFICATION CAHIER DES CHARGES	RSS-102 RSS-247	ISSUE EDITION	5 2
<p>Certification of equipment means only that the equipment has met the requirements of the above-noted specification. Licence applications, where applicable to use certified equipment, are acted on accordingly by the ISED issuing office and will depend on the existing radio environment, service and location of operation. This certificate is issued on condition that the holder complies and will continue to comply with the requirements and procedures issued by ISED. The equipment for which this certificate is issued shall not be manufactured, imported, distributed, leased, offered for sale or sold unless the equipment complies with the applicable technical specifications and procedures issued by ISED.</p>		<p>La certification du matériel signifie seulement que le matériel a satisfait aux exigences de la norme indiquée ci-dessus. Les demandes de licences nécessaires pour l'utilisation du matériel certifié sont traitées en conséquence par le bureau de délivrance d'ISDE et dépendent des conditions radio ambiantes, du service et de l'emplacement d'exploitation. Le présent certificat est délivré à la condition que le titulaire satisfasse et continue de satisfaire aux exigences et aux procédures d'ISDE. Le matériel à l'égard duquel le présent certificat est délivré ne doit pas être fabriqué, importé, distribué, loué, mis en vente ou vendu à moins d'être conforme aux procédures et aux spécifications techniques applicables publiées par ISDE.</p>		
<p>ISSUED BY TELEFICATION BV (NL0001), RECOGNIZED CERTIFICATION BODY BY INNOVATION, SCIENCE AND ECONOMIC DEVELOPMENT CANADA DELIVRÉ PAR TELEFICATION BV (NL0001), ORGANISME DE CERTIFICATION RECONNU PAR INNOVATION, SCIENCES ET DÉVELOPPEMENT ÉCONOMIQUE CANADA</p>				
<p><i>I hereby attest that the subject equipment was tested and found in compliance with the above-noted specification. J'atteste, par la présente, que le matériel a fait l'objet d'essai et a été jugé conforme à la spécification ci-dessus</i></p>				
DATE 25 Oct 2019 BY	Gürhan Vural Product Assessor			
This certificate has one annex.				

9.7. SRRC Certificate (China)

BLE 1Mbps & 2Mbps, IEEE 802.15.4 approved.



9.8. KC Certificate (South Korea)

BLE 1Mbps & 2Mbps, IEEE 802.15.4 approved.

2CC6-E6D4-B6AA-9E64

방송통신기자재등의 적합인증서 <i>Certificate of Broadcasting and Communication Equipments</i>	
상호 또는 성명 <i>Trade Name or Applicant</i>	Raytac Corporation
기자재명칭(명칭) <i>Equipment Name</i>	특정소출력 무선기기(무선데이터통신시스템용 무선기기)
기본모델명 <i>Basic Model Number</i>	MDBT50Q-U
파생모델명 <i>Series Model Number</i>	MDBT50Q, MDBT50Q-P
인증번호 <i>Certification No.</i>	R-C-ryt-MDBT50Q
제조사/제조국가 <i>Manufacturer/ Country of Origin</i>	Raytac Corporation / 대만
인증연월일 <i>Date of Certification</i>	2018-08-17
기타 <i>Others</i>	
<p>위 기자재는 「전파법」 제58조의2 제2항에 따라 인증되었음을 증명합니다. It is verified that foregoing equipment has been certificated under the Clause 2, Article 58-2 of Radio Waves Act.</p> <p style="text-align: right;">2018년(Year) 08월(Month) 17일(Day)</p> <p style="text-align: center;">국립전파연구원장 </p> <p style="text-align: center;"><i>Director General of National Radio Research Agency</i></p> <p style="text-align: center; font-size: small;">※ 인증 받은 방송통신기자재는 반드시 "적합성평가표시" 를 부착하여 유통하여야 합니다. 위반시 과태료 처분 및 인증이 취소될 수 있습니다.</p>	

9.9. RoHS & REACH Report

Please visit "[Support](#)" page of our website to download.

9.10. End-Product Label

It is suggested using following content adding to package or user manual or label to obey the regulation. Any rules of end-product label shall refer to each certification for final reference.

9.10.1. FCC (USA)

The FCC statement should be included in the user manual when there is no enough space on label. Otherwise, it should be included on the label.

“This device complies with part 15 of the FCC rules. Operation is subject to the following two conditions. (1) This device may not cause harmful interference. (2) This device must accept any interference received, including interference that may cause undesired operation.”

The final end product must be labeled in a visible area with the following: “Contain FCC ID: SH6MDBT50Q”.

9.10.2. TELEC (Japan)

When manufacturer is placing the product on the Japanese market, the product must be affixed with the following Specified Radio Equipment marking:



9.10.3. NCC (Taiwan)

請依下列標籤式樣自製標籤，標貼或印鑄於器材本體明顯處，始得販賣或公開陳列。

MDBT50Q-U Series

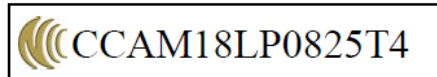

平台廠商必須於平台上標示字樣「本產品內含射頻模組：ID 編號 CCAM18LP0825T4」。

「平台」定義如下：若器材組裝本案模組，消費者仍能正常使用該器材主要功能，該器材得視為平台。若器材不組裝本案模組，消費者不能正常使用該器材主要功能，該器材不能視為平台。該類不同廠牌型號器材組裝本案審驗模組後，須分別申請型式認證。

9.10.4. IC (Canada)

The IC statement should be included in the user manual when there is no enough space on label. Otherwise, it should be included on the label.

“This device complies with Industry Canada license-exempt RSS Standard(s). Operation is subject to the following two conditions. (1) This device may not cause harmful interference. (2) This device must accept any interference received, including interference that may cause undesired operation.

Le présent appareil est conforme aux CNR d'Industrie Canada applicables aux appareils radio exempts de licence. L'exploitation est autorisée aux deux conditions suivantes: (1) l'appareil ne doit pas produire de brouillage, et (2) l'utilisateur de l'appareil doit accepter tout brouillage radioélectrique subi, même si le brouillage est susceptible d'en compromettre le fonctionnement.”

The final end product must be labeled in a visible area with the following: “Contain IC ID: 8017A-MDBT50QU”.

10. Notes and Cautions

Module is not designed to last for a lifetime. Like general products, it is expected to be worn out after continuous usage through the years. To assure that product will perform better and last longer, please make sure you:

- Follow the guidelines of this document while designing circuit/end-product. Any discrepancy of core Bluetooth technology and technical specification of IC should refer to definition of Bluetooth Organization and Nordic Semiconductor as final reference.
- Do not supply voltage that is not within range of specification.
- Eliminate static electricity at any cost when working with the module as it may cause damage. It is highly recommended adding anti-ESD components to circuit design to prevent damage from real-life ESD events. Anti-ESD methods can be also applied in mechanical design.
- Do not expose modules under direct sunlight for long duration. Modules should be kept away from humid and salty air conditions, and any corrosive gasses or substances. Store it within -40°C to $+125^{\circ}\text{C}$ before and after installation.
- Avoid any physical shock, intense stress to the module or its surface.
- Do not wash the module. No-Clean Paste is used in production. Washing it will oxidize the metal shield and have chemistry reaction with No-Clean Paste. Functions of the module are not guaranteed if it has been washed.

The module is not suitable for life support device or system and not allowed to be used in destructive device or systems in any direct or indirect ways. The customer agrees to indemnify Raytac for any losses when applying modules in applications such as the ones described above.

11. Basic Facts for nRF52 Family

Below chart shows basic spec for Nordic nRF52 family, which is helpful to understand the differences between each SoC. Any discrepancy shall refer to Nordic's technical document as final reference.

See [Full List of Raytac's BLE Modules](#) for complete model no. of each item.

Nordic Solution	nRF52840	nRF52833	nRF52820	nRF52832	nRF52810	nRF52811	nRF52805
RAYTAC Model No. (MDBTXX)	50Q series	50Q series 50 series	50 series	42Q series 42 series 42V series	42Q series	42Q Series	42T series 42TV series
Bluetooth Direction Finding		V	V			V	
Bluetooth 5 Long Range (125kbps)	V	V	V			V	
Bluetooth 5 High Speed	V	V	V	V	V	V	V
Bluetooth 5 Ad. Extention (x8)	V	V	V	V	V	V	V
Flash (kBytes)	1024	512	256	512	192	192	192
RAM (kBytes)	256	128	32	64	24	24	24
ANT Plus	V	V	V	V	V	V	
IEEE 802.15.4	V	V	V			V	
ARM® TrustZone® Cryptocell	V						
USB	V	V	V				
QSPI	V						
NFC	V	V		V			
I2S	V	V		V			
SPI, TWI, UART, PWM	V	V	V	V	V	V	without PWM
PDM	V	V		V	V	V	
ADC, Comparators	V	V	without ADC	V	V	V	without comparators
Supply Range (V)	1.7 to 5.5	1.7 to 5.5	1.7 to 5.5	1.7 to 3.6	1.7 to 3.6	1.7 to 3.6	1.7 to 3.6

12. Useful Links

- **Nordic Infocenter:** <https://infocenter.nordicsemi.com/index.jsp>
All the necessary technical files and software development kits of Nordic's chip are on this website.
- **Nordic DevZone:** <https://devzone.nordicsemi.com/questions/>
A highly recommended website for firmware developer. Interact, discuss and consult with other fellow developers and Nordic's employees to get answers to your questions. The site also includes tutorials in detail to help you get started.
- **Official Page of nRF52833 :**
<https://www.nordicsemi.com/Products/Low-power-short-range-wireless/nRF52833>
A brief introduction to nRF52833 and download links for Nordic's developing software and SoftDevices.

Full List of Raytac's BLE Modules

● MDBT40 Series

Series	Nordic Solution	Raytac No.	IC Ver.	Antenna	RAM	Flash Memory
MDBT40	nRF51822	MDBT40-256V3	3	Chip Antenna	16 kb	256 K
		MDBT40-256RV3			32 kb	256 K
MDBT40-P	nRF51822	MDBT40-P256V3	3	PCB Antenna	16 kb	256 K
		MDBT40-P256RV3			32 kb	256 K

● MDBT42Q Series (QFN Package IC)

Series	Nordic Solution	Raytac No.	IC Ver.	Antenna	RAM	Flash Memory
MDBT42Q	nRF52832	MDBT42Q-512KV2	2	Chip Antenna	64 kb	512 K
	nRF52810	MDBT42Q-192KV2	2		24 kb	192 K
	nRF52811	MDBT42Q-192KL	1			
MDBT42Q-P	nRF52832	MDBT42Q-P512KV2	2	PCB Antenna	64 kb	512 K
	nRF52810	MDBT42Q-P192KV2	2		24 kb	192 K
	nRF52811	MDBT42Q-P192KL	1			
MDBT42Q-U	nRF52832	MDBT42Q-U512KV2	2	u.FL Connector	64 kb	512 K

● MDBT42 Series (WLCSP Package IC)

Series	Nordic Solution	Raytac No.	IC Ver.	Antenna	RAM	Flash Memory
MDBT42	nRF52832	MDBT42-512KV2	2	Chip Antenna	64 kb	512 K
MDBT42-P		MDBT42-P512KV2		PCB Antenna		

● MDBT42V Series (WLCSP Package IC)

Series	Nordic Solution	Raytac No.	IC Ver.	Antenna	RAM	Flash Memory
MDBT42V	nRF52832	MDBT42V-512KV2	2	Chip Antenna	64 kb	512 K
MDBT42V-P		MDBT42V-P512KV2		PCB Antenna		

● MDBT42T Series (WLCSP Package IC)

Series	Nordic Solution	Raytac No.	IC Ver.	Antenna	RAM	Flash Memory
MDBT42T	nRF52805	MDBT42T-192K	1	Chip Antenna	24 kb	192 K
MDBT42T-P		MDBT42T-P192K		PCB Antenna		

● MDBT42TV Series (WLCSP Package IC)

Series	Nordic Solution	Raytac No.	IC Ver.	Antenna	RAM	Flash Memory
MDBT42TV	nRF52805	MDBT42TV-192K	1	Chip Antenna	24 kb	192 K
MDBT42TV-P		MDBT42TV-P192K		PCB Antenna		

● MDBT50Q Series (aQFN Package IC)

Series	Nordic Solution	Raytac No.	IC Ver.	Antenna	RAM	Flash Memory
MDBT50Q	nRF52840	MDBT50Q-1MV2	2	Chip Antenna	256 kb	1 MB
	nRF52833	MDBT50Q-512K	1		128 kb	512 kb
MDBT50Q-P	nRF52840	MDBT50Q-P1MV2	2	PCB Antenna	256 kb	1 MB
	nRF52833	MDBT50Q-P512K	1		128 kb	512 kb
MDBT50Q-U	nRF52840	MDBT50Q-U1MV2	2	u.FL Connector	256 kb	1 MB
	nRF52833	MDBT50Q-U512K	1		128 kb	512 kb
Dongle	nRF52840	MDBT50Q-RX	1, 2	PCB Antenna	256 kb	1 MB

● MDBT50 Series (QFN Package IC)

Series	Nordic Solution	Raytac No.	IC Ver.	Antenna	RAM	Flash Memory
MDBT50	nRF52820	MDBT50-256R	1	Chip Antenna	32 kb	256 kb
	nRF52833	MDBT50-512K	1		128 kb	512 kb
MDBT50-P	nRF52820	MDBT50-P256R	1	PCB Antenna	32 kb	256 kb
	nRF52833	MDBT50-P512K	1		128 kb	512 kb

● MDBT53 Series (WLCSP Package IC)

Series	Nordic Solution	Raytac No.	IC Ver.	Antenna	RAM	Flash Memory
MDBT53	nRF5340	MDBT53-1M	1	Chip Antenna	512 kb	1 MB
MDBT53-P	nRF5340	MDBT53-P1M	1	PCB Antenna	512 kb	1 MB
MDBT53-U	nRF5340	MDBT53-U1M	1	u.FL Connector	512 kb	1 MB

● MDBT53V Series (WLCSP Package IC)

Series	Nordic Solution	Raytac No.	IC Ver.	Antenna	RAM	Flash Memory
MDBT53V	nRF5340	MDBT53V-1M	1	Chip Antenna	512 kb	1 MB
MDBT53V-P	nRF5340	MDBT53V-P1M	1	PCB Antenna	512 kb	1 MB

Release Note

- 2019/11/15 Pre-release

- 2019/12/30 Version A (1st release)

- 2020/01/03 Version B
 - (1) Corrected illustration of pin definition in section 2.

- 2020/06/23 Version C:
 - (1) Refined description and updated graph in section 3 of Chapter 2.
 - (2) Updated information of Tape & Reel and order code in Chapter 4: Shipment Packaging Information
 - (3) Updated Chapter 5: Specification based on nRF52833 Production Specification v1.2.
 - (4) Corrected note “D-“ and “D+” in Chapter 8: Reference Circuit
 - (5) Updated CE reports to EN300.328 V2.2.2 & EN62368-1.
 - (6) Updated Full List of Raytac’s BLE modules.

- 2020/12/30 Version D
 - (1) Updated information of T&R in Chapter 4: Shipment Packaging Information.
 - (2) Added BT 5.2 SIG approval and corrected SRRC certificate in Chapter 9: Certification.
 - (3) Updated table in Chapter 11: Basic Facts for nRF52 Family.
 - (4) Updated Full List of Raytac’s BLE Modules

- 2021/06/07 Version E
 - (1) Updated graph in section 2 of Chapter 2: Product Dimension.
 - (2) Updated MPQ information for T&R package in Chapter 4: Shipment Packaging Information.
 - (3) Updated Chapter 5: Specification corresponding to Nordic’s new nRF52833 Product Specification V1.3

- 2022/07/01 Version F
 - (1) Updated Chapter 4: 4.2.1 Tray Packaging with 4.2.2 Tape & Reel Packaging info.

(2) Updated List of Raytac's Model no.

(3) Corrected Schematic and info in Chapter 8: Reference Circuit.

(4) Updated Chapter 5: Specification corresponding to Nordic's new nRF52833 Product Specification V1.5.

- 2023/05/24 Version G

(1) Updated drawing in Chapter 2 for a better understanding of PCB measurement & RF Layout Suggestion.

